

843WD CLAMSHELL LATHE

MACTECH PORTABLE MACHINING SOLUTIONS

Features

- Sever or simultaneous Sever/Bevel 31 to 43 inch diameter pipe, or NPS 32 to NPS 42 schedule pipe.
- Cold cutting in hazardous environments.
- Exceptionally rigid, split-frame for precise on-site machining.
- Lightweight, low clearance design for easy handling in tight working spaces.
- Tool Holder accepts standard 3/4 or 1 inch tool bits.
- Air Caddy (air filter and oiler) included with air drive systems.
- Custom setups and drives available for your application.

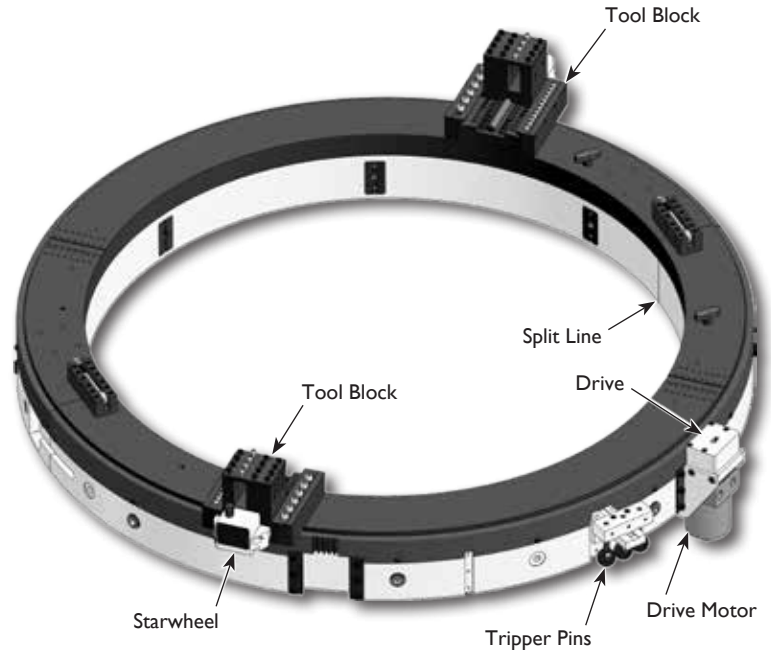

Mactech 843WD Clamshell Lathe

843WD Nominal Pipe Size (NPS) Application Range

Nominal Pipe Size (in.)	Schedule No.	Wall Thickness (in.)	Inside Diameter (in.)	Nominal Pipe Size (in.)	Schedule No.	Wall Thickness (in.)	Inside Diameter (in.)	
32 (32.000)	10	0.312	31.376	36 (36.000)	10	0.312	35.375	
	ST	0.375	31.250		ST, 40S	0.375	35.250	
	20	0.500	31.000		XS, 80S	0.500	35.000	
	30	0.625	30.750		42 (42.000)	ST, 40S	0.375	41.250
	40	0.688	30.624			XS, 80S	0.500	41.000
34 (34.000)	10	0.312	33.376	30	0.625	40.750		
	ST	0.375	33.250	40	0.750	40.500		
	20	0.500	33.000					
	30	0.625	32.750					
	40	0.688	32.624					

Options

- Full line of tool bits
- Right angle and reversible drives
- Single Point machining attachment
- Axial Feed machining attachment
- Counterbore/Facing attachment
- Hydraulic Power Unit

Application Range

31.00 to 43.00 inch (787 to 1092 mm) diameter pipe, or NPS 32 to NPS 42 schedule pipe.

Feed

Feed Mechanism: 4 point starwheel with 3-pin tripper feed.
Feed Rate: .002, .004 or .006 inches per revolution (0.05, 0.11 or 0.16 mm).

Drives

Air Drive

Air supply requirement: 100 cfm @100 psi (2.8 m³/min @ 6.9 bar)

Hydraulic Drive

HPU requirement: 10-15 gpm @ 1000 psi (38-57 lpm @ 69 bar) continuous pressure
Hydraulic motor includes hose whips and quick-disconnects

Weights (includes tool blocks and motor)

Operating Weights

843WD Air Drive: 695 lbs. (315 kg)
843WD Hydraulic Drive: 707 lbs. (321 kg)

Shipping Weights

843WD Air Drive: 1100 lbs. (499 kg)
843WD Hydraulic Drive: 1112 lbs. (504 kg)



Mactech, Inc. • 4079 Pepin Ave. • Red Wing, MN 55066
PH: 651-388-7117 • TOLL FREE: 800-328-1488 • FAX: 651-388-0337
www.mactechonsite.com

843WD CLAMSHELL LATHE

MACTECH PORTABLE MACHINING SOLUTIONS

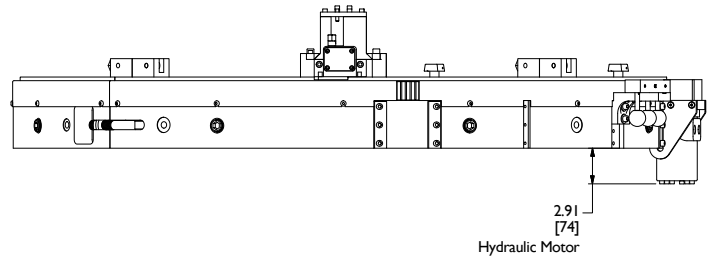
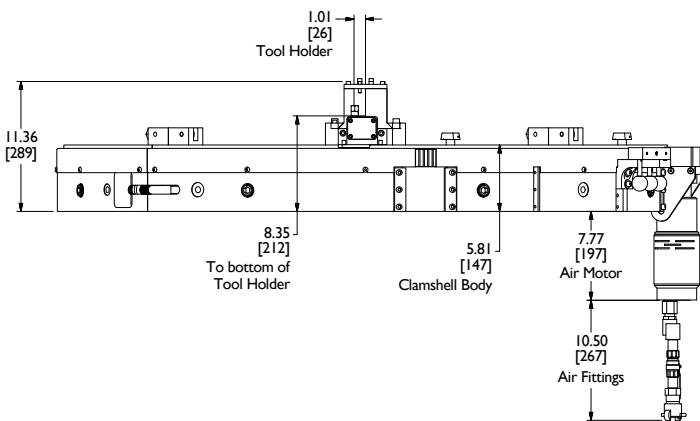
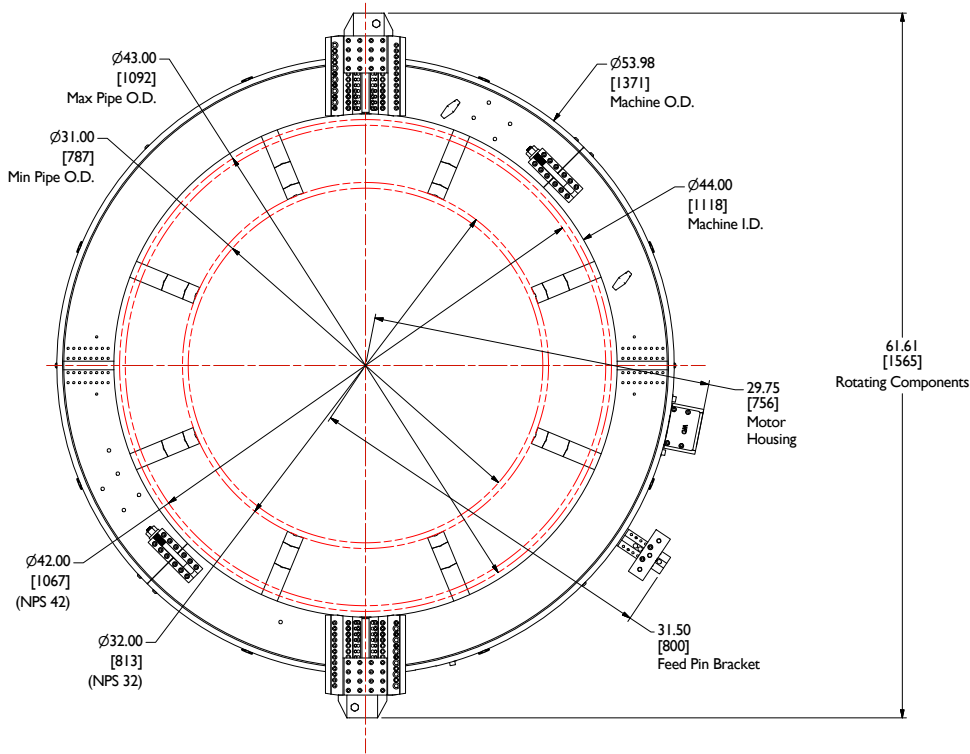

Mactech, Inc. • 4079 Pepin Ave. • Red Wing, MN 55066
 PH: 651-388-7117 • TOLL FREE: 800-328-1488 • FAX: 651-388-0337
www.mactechonsite.com