

AutoSPLITTER Nut Splitter



- **Designed for Speed & Safety**
- **Designed for Operator Comfort**
- **Removes Corroded Nuts Fast**
- **Removes Frozen Nuts Safely**
- **Fits Tight Spaces**
- **Cuts through the Hardest Nuts**

LEADING PROVIDER OF BOLT LOADING & REMOVAL SOLUTIONS

Products and Prices are subject to updates and changes. Please contact us for current quote.

2013

AutoSPLITTER

With **FACTORQ's AutoSPLITTER**, you can cut through the largest frozen nuts in just seconds, with virtually no risk of injury or accident. It's easy. Simply slip the AutoSPLITTER head over the nut and apply hydraulic pressure. One cut frees even the most corroded nut so it can be turned. Or make two cuts, 180 degrees apart, to cleanly cut the nut away.

The benefits add up:

FAST:

To remove a 3-1/2" nut with a torch or hammer and chisel might take up to 20 minutes. But you only need 20-30 seconds with AutoSPLITTER. Fast set-up too. AutoSPLITTER goes from the toolbox to in-use in less than five minutes.

SAFE:

No hammers, No impact. Operator has hands off during operation. No flames. No risk to volatile environments. No hot work permits required. AutoSPLITTER cuts smoothly so that there is no danger to the operator or the surrounding equipment.

**CUSTOM
SIZES
AVAILABLE**



*AutoSPLITTER cuts from 5/8" to 6-1/2" (16 - 165 mm) across the flats hexagonal nuts. You can use it for both inch and metric sizes, and with virtually any shape nut. **Round, square, 12-point and other special nuts will require the use of an adapter.** Also available, are adapters for splitting huck bolts.*

QUIET:

All you'll hear is the hum of the hydraulic pump and a reassuring "snap" when the nut is cut. With AutoSPLITTER, there's no noise pollution or risk of noise-related injury.

PRECISE:

You can easily calibrate the cutting chisel so only the nut is cut, with no damage to the bolt or stud threads.

VERSATILE:

AutoSPLITTER cuts through even the hardest nuts, including 2H (ASTM A 194/2H {Brinell hardness 248-352}). And each model of AutoSPLITTER can be used for a wide range of inch or metric nut sizes (see charts).

MONEY SAVING:

Nut removal takes less time, so downtime is reduced. And with AutoSPLITTER, you can avoid costly damage to bolts, studs and surrounding equipment.

AutoSPLITTER outperforms and outlasts the competition

Compare AutoSPLITTER with any other nut-splitter on the market. You'll find AutoSPLITTER wins hands down.

It's more versatile.

One AutoSPLITTER does the work of several competitive models because each housing can be used with a wide range of nut sizes. With most other nut-splitters, one housing will only fit two nut sizes, forcing you to buy a larger number of housings. But each AutoSPLITTER housing fits 6-8 different sizes. With AutoSPLITTER, you can also use the hydraulic cylinders with more than one housing.

It's more flexible.

AutoSPLITTER's specially designed, so you can work from more angles and in more applications than with competitor's models. AutoSPLITTER fits all API and ANSI flanges and virtually all valve bonnets.

It's more durable.

AutoSPLITTERS are made to last. Our special metallurgy, hardening process and sharpening methods make our chisels good for dozens of cuts before resharpening - and many resharpenings before replacing!



AutoSPLITTER's specially designed housing fits into tight spaces, so you can work from more angles and in more applications than with competitors' models. Paint, corrosion and nuts with rounded corners are no problem. Fits all API and ANSI flanges and virtually all valve bonnets.



Cuts the Nut Without Damaging the Stud

STANDARD MODELS

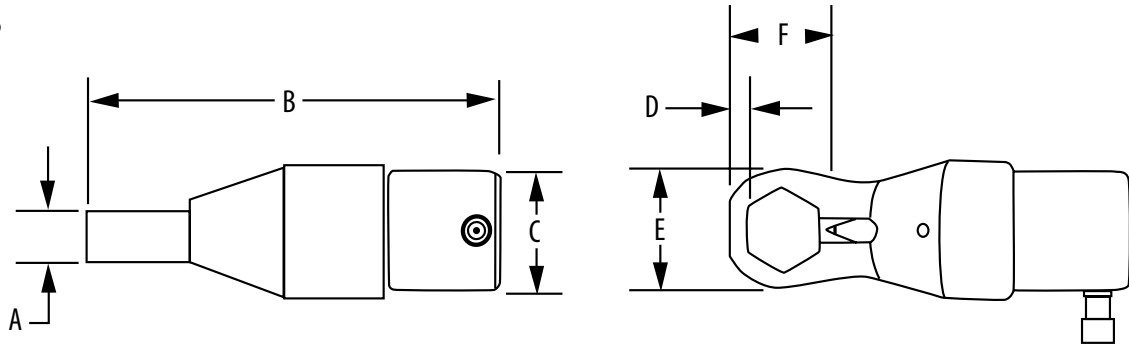

AutoSPLITTER Dimensions

	STRAIGHT HEAD MODEL	Stud Diameter in (MM)	Nut Size A.T.F. in (MM)	"A" in (MM)	"B" in (MM)	"C" in (MM)	"D" in (MM)	"E" in (MM)	"F" in (MM)	Approx. Weight LBS (KG)
AS-DUO 25	AS105	7/16" - 7/8" (11.1MM - 22.2MM)	5/8" - 1 7/16" (15.9MM - 36.5MM)	1 1/2" (38.1MM)	11" (279.4MM)	3.969" (100.8MM)	0.421" (10.7MM)	2.867" (72.8MM)	7.479" (190.0MM)	20LBS (9.1KG)
	AS200	7/8" - 1 1/4" (22.2MM - 31.8MM)	1 5/16" - 2" (33.3MM - 50.8MM)	1 1/2" (38.1MM)	11 3/4" (298.5MM)	3.969" (100.8MM)	1/2" (12.7MM)	3.618" (91.9MM)	8.001" (203.2MM)	21LBS (9.5KG)
AS-DUO 55	AS204	1 1/4" - 1 1/2" (31.8MM - 38.1MM)	1 7/8" - 2 3/8" (47.6MM - 60.3MM)	2 1/4" (57.2MM)	16.100" (408.9MM)	6" (152.4MM)	0.687" (17.4MM)	3.903" (99.1MM)	11.474" (291.4MM)	61LBS (27.7KG)
	AS210	1 3/8" - 1 3/4" (39.4MM - 44.5MM)	2 1/16" - 2 3/4" (52.4MM - 70MM)	2 1/4" (57.2MM)	16.100" (408.9MM)	5.969" (151.6MM)	0.672" (17.1MM)	4.500" (114.3MM)	11.375" (288.9MM)	62LBS (28.1KG)
AS-DUO 100	AS308	1 3/4" - 2 1/4" (44.5MM - 57.2MM)	2 5/8" - 3 1/2" (66.7MM - 88.9MM)	3" (76.2MM)	17.750" (450.9MM)	7 1/8" (181.0MM)	0.875" (22.2MM)	5 3/4" (146.1MM)	17 3/4" (450.9MM)	95LBS (43.1KG)
	AS314	2" - 2 1/2" (50.8MM - 63.5MM)	3" - 3 7/8" (76.2MM - 98.4MM)	3 1/8" (79.4MM)	18" (457.2MM)	7 1/8" (181.0MM)	0.875" (22.2MM)	6 1/4" (158.8MM)	18" (457.2MM)	100LBS (45.4KG)
AS-TRIO	AS404	2 1/2" - 2 3/4" (63.5MM - 69.9MM)	3 3/4" - 4 1/4" (95.3MM - 108MM)	3 3/4" (95.25MM)	22 3/4" (577.9MM)	9.875" (250.8MM)	1 1/8" (28.6MM)	7 1/2" (190.5MM)	18" (457.2MM)	205LBS (93KG)
	AS500	3" - 3 1/4" (76.2MM - 82.6MM)	4 1/2" - 5" (114.3MM - 127MM)	4 1/8" (104.8MM)	23" (584.2MM)	9.875" (250.8MM)	1 1/8" (28.6MM)	9" (228.6MM)	19 1/4" (489.0MM)	210LBS (95.3KG)
	AS506	3 1/4" - 3 1/2" (76.2MM - 88.9MM)	4 7/8" - 5 3/8" (123.8MM - 136.5MM)	4 1/8" (104.8MM)	23 1/8" (587.4MM)	9.875" (250.8MM)	1 1/8" (28.6MM)	9.375" (238.1MM)	19 1/2" (495.3MM)	215LBS (97.5KG)
	AS608	3 3/4" - 4" (95.3MM - 101.6MM)	5 5/8" - 6 1/8" (142.9MM - 155.6MM)	5" (127.0MM)	24" (609.6MM)	12 1/2" (317.5MM)	1.406" (35.7MM)	11.720" (297.7MM)	22" (558.8MM)	387LBS (175.5KG)



Cuts the Nut Without Damaging the Stud

ANGLE HEAD MODELS

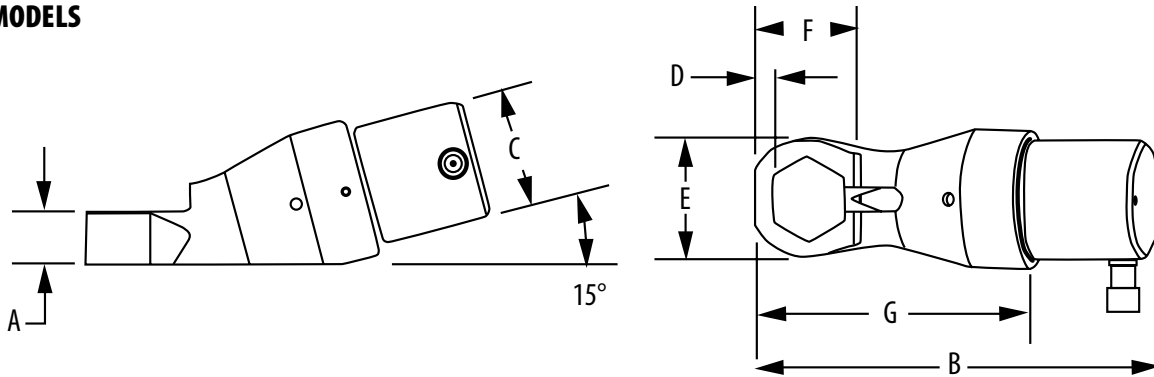

AutoSPLITTER Dimensions

	ANGLE HEAD MODEL	Stud Diameter in (MM)	Nut Size A.T.F. in (MM)	"A" in (MM)	"B" in (MM)	"C" in (MM)	"D" in (MM)	"E" in (MM)	"F" in (MM)	Approx. Weight LBS (KG)
	AS100AH	5/16" - 5/8" (7.9MM - 15.9MM)	1/2" - 1 1/16" (12.7MM - 27MM)	0.725" (18.4MM)	8" (203.2MM)	2 3/4" (69.9MM)	1/4" (6.4MM)	2" (50.8MM)	5.533" (104.5MM)	7LBS (3.2KG)
AS-DUO 25AH	AS105AH	7/16" - 7/8" (11.1MM - 22.2MM)	5/8" - 1 7/16" (15.9MM - 36.5MM)	1 1/8" (28.6MM)	11" (279.4MM)	3.969" (100.8MM)	0.437" (11.1MM)	2.867" (72.8MM)	7.438" (188.9MM)	20LBS (9.1KG)
	AS200AH	7/8" - 1 1/4" (22.2MM - 31.8MM)	1 5/16" - 2" (33.3MM - 50.8MM)	1 3/8" (34.9MM)	11 3/4" (298.5MM)	3.969" (100.8MM)	1/2" (12.7MM)	3.618" (91.9MM)	7.938" (201.6MM)	21LBS (9.5KG)
AS-DUO 55AH	AS204AH	1 1/4" - 1 1/2" (31.8MM - 38.1MM)	1 7/8" - 2 3/8" (47.6MM - 60.3MM)	1 3/4" (44.5MM)	16.100" (408.9MM)	6" (152.4MM)	0.687" (17.4MM)	3.984" (101.2MM)	11.490" (291.8MM)	61LBS (27.7KG)
	AS210AH	1 3/8" - 1 3/4" (39.4MM - 44.5MM)	2 1/16" - 2 3/4" (52.4MM - 70MM)	2" (50.8MM)	16.100" (408.9MM)	5.969" (151.6MM)	3/4" (19.1MM)	4.500" (114.3MM)	12.062" (306.4MM)	62LBS (28.1KG)
AS-DUO 100AH	AS308AH	1 3/4" - 2 1/4" (44.5MM - 57.2MM)	2 5/8" - 3 1/2" (66.7MM - 88.9MM)	3.630" (92.2MM)	19.640" (498.9MM)	7 1/4" (184.2MM)	3/4" (19.1MM)	6 1/4" (158.8MM)	13 1/4" (336.6MM)	95LBS (43.1KG)
	AS314AH	2" - 2 1/2" (50.8MM - 63.5MM)	3" - 3 7/8" (76.2MM - 98.4MM)	3 1/8" (79.4MM)	20.14" (511.6MM)	7 1/4" (184.2MM)	0.875" (22.2MM)	6 3/4" (171.5MM)	13 3/4" (449.3MM)	100LBS (45.4KG)



Cuts the Nut Without Damaging the Stud

ANGLE HEAD DOUBLE-CUT MODELS

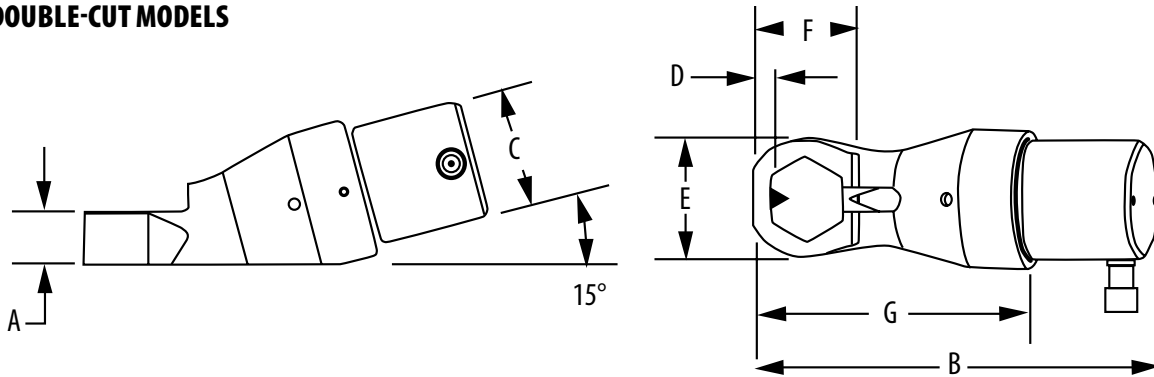

AutoSPLITTER Dimensions

DOUBLE CUT MODEL	Stud Diameter in (MM)	Nut Size A.T.F. in (MM)	"A" in (MM)	"B" in (MM)	"C" in (MM)	"D" in (MM)	"E" in (MM)	"F" in (MM)	Approx. Weight LBS (KG)
AS100AH-DC	5/16" - 1/2" (7.9MM - 15.7MM)	1/2" - 3/4" (12.7MM - 19.1MM)	0.725" (18.4MM)	8" (203.2MM)	2 3/4" (69.9MM)	0.778" (19.8MM)	1" (25.4MM)	5 3/4" (146.1MM)	7LBS (3.2KG)
AS105AH-DC	7/16" - 3/4" (11.1MM - 19.05MM)	5/8" - 1 1/4" (15.9MM - 31.75MM)	1 1/8" (28.6MM)	11" (279.4MM)	3.969" (100.8MM)	0.914" (23.2MM)	1.434" (36.4MM)	7.590" (192.8MM)	20LBS (9.1KG)
AS200AH-DC	7/8" - 1" (22.2MM - 25.4MM)	1 7/16" - 1 5/8" (36.5MM - 41.28MM)	1 1/2" (38.1MM)	11.44" (290.58MM)	4" (101.6MM)	1/2" (12.7MM)	3.624" (92.05MM)	4" (101.6MM)	21LBS (9.5KG)
AS204AH-DC	1 1/4" - 1 3/8" (31.8MM - 34.9MM)	1 7/8" - 2 3/16" (47.6MM - 55.6MM)	1 3/4" (44.5MM)	16.100" (408.9MM)	6" (152.4MM)	1.507" (38.3MM)	2.240" (56.9MM)	11.993" (304.6MM)	61LBS (27.7KG)
AS210AH-DC	1 3/8" - 1 1/2" (34.9MM - 38.1MM)	2 1/16" - 2 3/8" (52.4MM - 60.3MM)	2" (50.8MM)	16.100" (408.9MM)	5.969" (151.6MM)	1.388" (35.3MM)	4 3/4" (120.7MM)	12.187" (309.5MM)	62LBS (28.1KG)
AS308AH-DC	1 3/4" - 2 1/4" (44.5MM - 57.2MM)	2 5/8" - 3 1/2" (66.7MM - 88.9MM)	3.630" (92.2MM)	19.640" (498.9MM)	7 1/4" (184.2MM)	1.725" (43.8MM)	6 1/4" (158.8MM)	13 1/4" (336.6MM)	95LBS (43.1KG)

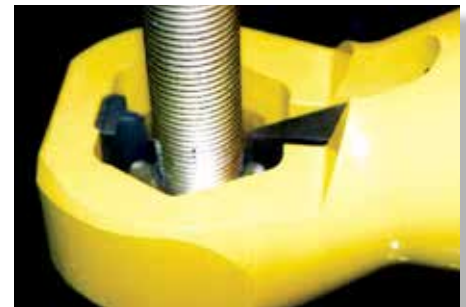

Power Units for AutoSPLITTER models

All AutoSPLITTER models require 10,000 PSI hydraulic pumps (sold separately). We supply electric, air and manually driven power units. When electricity or air power are not available, select from Models 100H or 150H. With each pump you will receive 12 feet of hydraulic hose plus all fittings and quick disconnects needed. Just like the quality you rely on from all our tools, Fastorq Power Units are designed to handle your most challenging needs without fail!

SPEED: More speed, power and durability than any other power unit in the industry.

ACCURACY AND EASE: Set the torque and with the touch of a button.

VERSATILITY: Get the power and control you need in a complete range, from 150 to 150,000 ft./lbs.

RELIABILITY: Every power unit is fully tested by FASTORQ® technicians and is delivered ready for operation complete with the necessary hoses, controllers and quick disconnects.

THE DIFFERENCE: Competitive power units utilize 2-stage pumps. The first stage provides a high flow rate (speed) up to 1,000 psi (10% of torque capacity). When the torque requirement exceeds 10% (1,000 psi), the second stage takes over and the flow rate (speed) is reduced to one tenth (see chart).

115E, 215E - ELECTRIC

- 110/220 volts A/C and 115 volt A/C.
- Maximum pressure to 10,000 psi.
- Dump and 4-way valve models.
- Motor sizes from 1/2 to 1.5 hp.

105A, 205A - AIR

- 40 psi to 120 psi.
- Maximum pressure to 10,000 psi (30,000 psi for stud tensioner units).
- 2- and 4-way valve models.
- Motor sizes from 1/4 to 6 hp.

100H, 150H - MANUAL

- Foot-powered, single- and two-speed models available.
- Maximum pressure to 10,000 psi.
- Per stroke range .99 @ 200 psi to .662 @ 325 psi.

