



FLANGE TOOL INNOVATION

INFORMATION SHEET

TRAINING & DEMONSTRATION

FULL-SCALE MOBILE
TRAINING & DEMO PACKAGE

EXCLUSIVE DISTRIBUTOR OFFER

TRAINING & DEMONSTRATION
RIG WEIGHT:

230kg (507lb)

TRAINING & DEMONSTRATION PACKAGE:

1 x Training & Demonstration Rig
1 x Training Course at Equalizer Aberdeen HQ
Note: Training & Demonstration Rig must only be operated by users who have completed the training course

DEMONSTRATION TOOLS (INCLUDED)

1 x set of unpackaged Demonstration Tools (excludes individual cases, pumps and hoses):

FA1TM;
FA4TM;
FA9TE;
MG7TM;
FC10TE;
SWi12/14TM;
SWi20/25TE;
SWi20/25TI
SWi SAFETY BLOCK SMALL & LARGE;
SWi STEPPED BLOCKS;
SG4TM ;
SG11TM;
SG18TE;
M20, M33, M48 & M60COLLETS;
HP350S; HP350D; HP550S;
2 x 2m HYDRAULIC HOSE;
3/8" & 1/2" TORQUE WRENCHES;
1/2" POWER BAR;
6" & 12" VERNIER CALLIPERS

1x full set of hanging brackets for fixing to wall (minimum 18mm plywood recommended)

GRAPHICS KIT: (INCLUDED)

USB stick containing:

Set digital graphics for local printing:

Large Format Flange Types Sticker
Large Format Kit Inventory Sticker
Equalizer Branded Pop-Up Display Stand
Trailer External printed vinyl livery set of

Tool Instruction Manuals; Powerpoint Slides

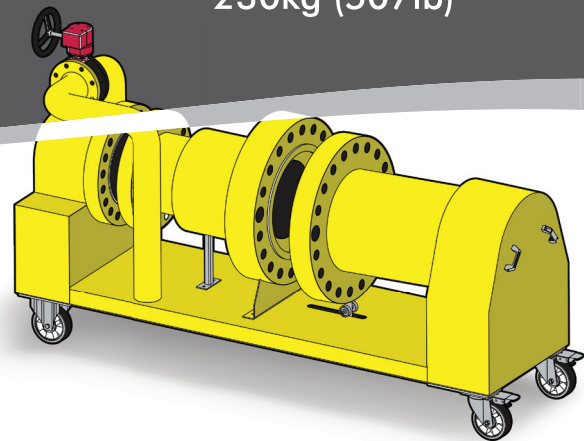

TRAINING & DEMONSTRATION RIG DIMENSIONS

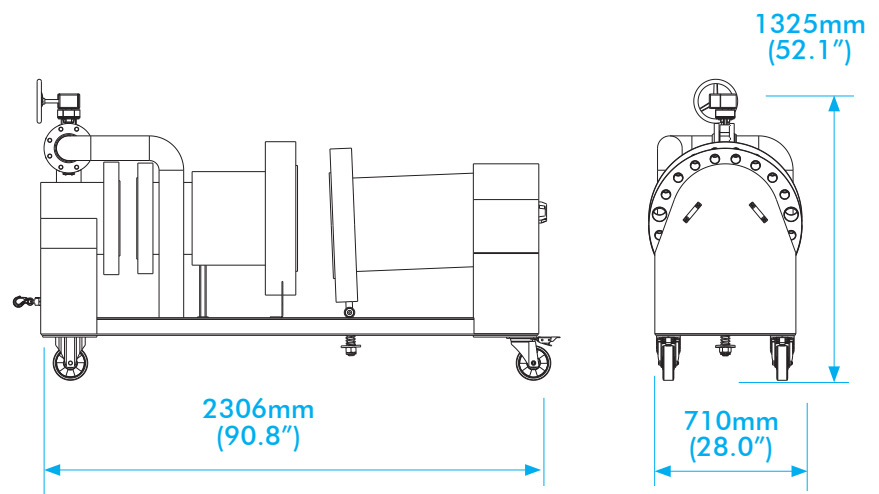

info@equalizerinternational.com
www.equalizerinternational.com

TRAINING & DEMONSTRATION

FULL-SCALE MOBILE TRAINING & DEMO PACKAGE



FLANGE TOOL INNOVATION

TRAINING & DEMONSTRATION RIG FEATURES

