

# SG13TE, SG15TE

## SECURE-GRIP HYDRAULIC FLANGE SPREADERS

Operator Instruction Manual



**EQUALIZER**<sup>TM</sup>  
INTERNATIONAL

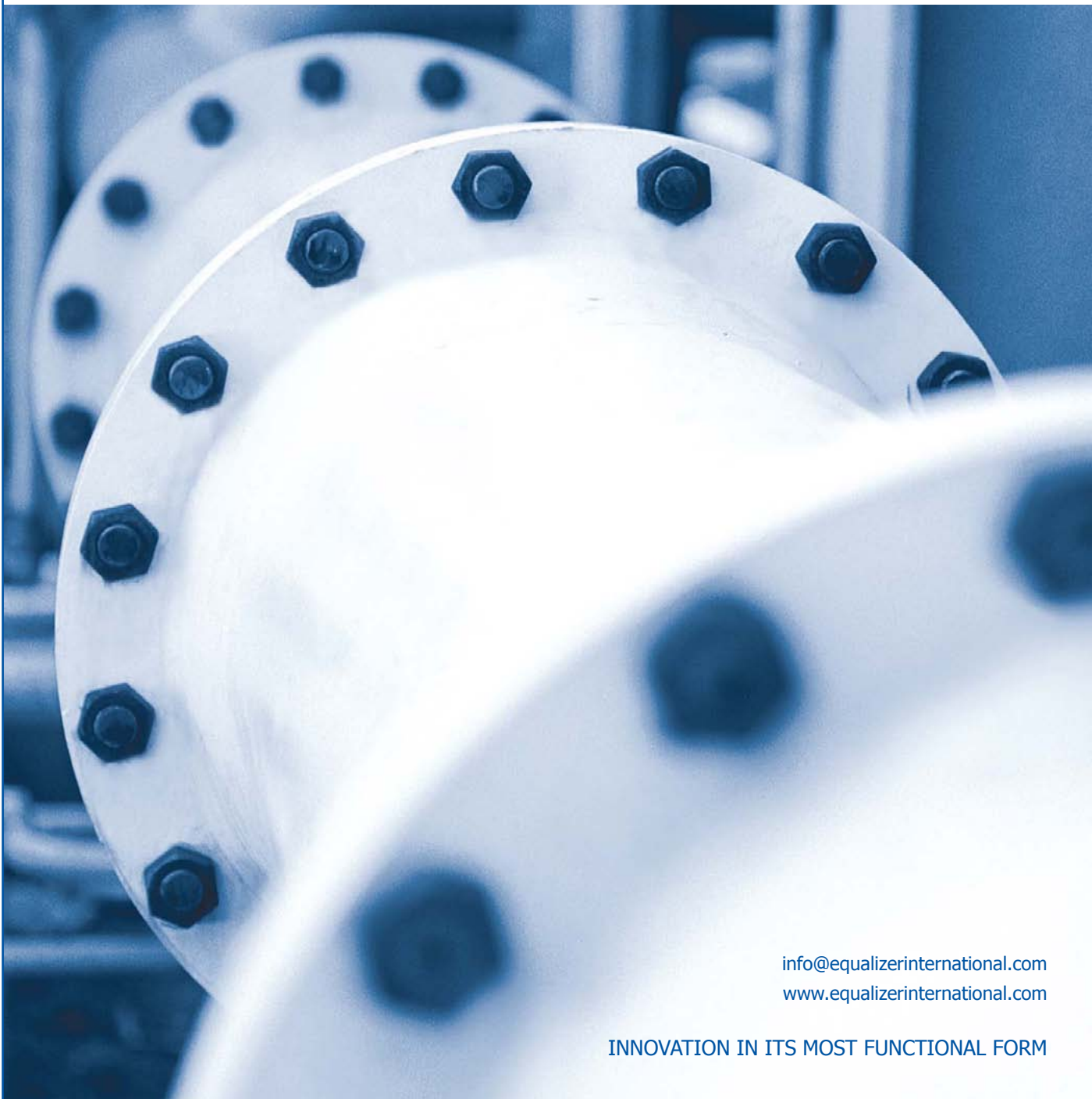

[info@equalizerinternational.com](mailto:info@equalizerinternational.com)  
[www.equalizerinternational.com](http://www.equalizerinternational.com)

INNOVATION IN ITS MOST FUNCTIONAL FORM



## INDEX

SECTION	CONTENTS	PAGE NO.
1	INTRODUCTION	1
2	SAFETY INFORMATION	2-3
3	KIT COMPONENTS	4
4	TECHNICAL DATA	5
5	HOW THE SECURE-GRIP HYDRAULIC TOOLS WORK	6
6	INSTALLATION AND OPERATION	7
	6.1 COLLET SELECTION BASED ON FLANGE SPECIFICATION	7
	6.2 COLLET SELECTION BASED ON BOLT-HOLE MEASUREMENT	8-10
	6.3 COLLET REMOVAL AND REPLACEMENT	11
	6.4 STANDARD INSTALLATION AND OPERATION	12-16
	6.5 RESTRICTED ACCESS INSTALLATION AND OPERATION	17
	6.6 VALVE, SPADE OR BLIND REMOVAL INSTALLATION AND OPERATION	18
7	MAINTENANCE AND LUBRICATION	19-20
8	PARTS LISTS	21-23
9	WEIGHTS AND DIMENSIONS	24
10	TROUBLESHOOTING	25-28
11	SECURE-GRIP TOOL RANGE	29
12	RANGE OF APPLICATION CHARTS	30-39

## 1. INTRODUCTION

The Equalizer Secure-Grip Flange Spreading Tools are a range of tools designed to assist in the maintenance and installation of pipeline flange assemblies.

The Hydraulic Secure-Grip Flange Spreading Tools are used to spread flanges with little or no access gap producing a spreading force of up to:

- **26T (260kN)** for the **SG13TE** when used in pairs
- **30T (300kN)** for the **SG15TE** when used in pairs

## 2. SAFETY INFORMATION

**The operator MUST read this manual prior to using the tools.**

**Failure to comply with the following cautions and warnings could cause equipment damage and personal injury; read the manual fully!**

Read all the following instructions, warnings and cautions carefully. Follow all safety precautions to avoid personal injury or property damage during system operation.

Equalizer International Ltd cannot be responsible for damage or injury resulting from unsafe product use, lack of maintenance or incorrect product and/or system operation. Contact Equalizer International Ltd when in doubt as to the safety precautions and applications. To protect your warranty, use only good quality hydraulic oil of the grade 32cSt.

Only people competent in the use of hydraulic equipment should use these tools.

In all installations the site safety requirements must be adhered to. ALSO the safety of the operator, and when present, any assisting personnel, is of paramount importance along with the safety of others including, when present, the general public.

These instructions are only to cover the safe operation of THE EQUALIZER SG13TE & SG15TE SECURE-GRIP HYDRAULIC TOOLS during normal maintenance/installation operations. All other safety aspects must be controlled by the operation supervisor.

A **CAUTION** is used to indicate correct operating or maintenance procedures and practices to prevent damage to, or destruction of equipment or other property.

A **WARNING** indicates a potential danger that requires correct procedures or practices to avoid personal injury.

A **DANGER** is only used when your action or lack of action may cause serious injury or even death.



**IMPORTANT:** Operator must be competent in the use of hydraulic equipment. The operator must have read and understood all instructions, safety issues, cautions and warnings before starting to operate the Equalizer equipment.



**WARNING:** To avoid personal injury and possible equipment damage, make sure all hydraulic components are rated to a safe working pressure of 700 bar (10,000 psi)



**WARNING:** Do not overload equipment. Overloading causes equipment failure and possible personal injury.

The risk of overloading can be avoided by using the Equalizer Hand Pump, which has its safety valve set to 700 bar by the factory. If alternative pumps are used, ensure they are rated at a safe working pressure of 700 bar (10,000 psi).



**CAUTION:** Make sure that all system components are protected from external sources of damage, such as excessive heat, flame, moving machine parts, sharp edges and corrosive chemicals.



**CAUTION:** Avoid sharp bends and kinks that will cause severe back-up pressure in hoses. Bends and kinks lead to premature hose failure. Do not drop heavy objects onto hoses. A sharp impact may cause internal damage to hose wire strands; applying pressure to a damaged hose may cause it to rupture. Do not place heavy weights on the hoses, or allow vehicles to roll over the hoses; crush damage will lead to premature hose failure.



**WARNING:** Immediately replace worn or damaged parts with genuine Equalizer parts. Equalizer parts are designed to fit properly and withstand rated loads. For repair or maintenance service contact your Equalizer distributor or service centre.



**DANGER:** To avoid personal injury keep hands and feet away from the tool and workpiece during operation.



**WARNING:** Always wear suitable clothing and Personal Protective Equipment (PPE).



**DANGER:** Do not handle pressurised hoses. Escaping oil under pressure can penetrate the skin, causing serious injury. If oil is injected under the skin, seek medical attention immediately.



**WARNING:** Never pressurize unconnected couplers. Only use hydraulic equipment in a connected system.



**IMPORTANT:** Do not lift hydraulic equipment by the hoses or couplers. Use the carrying handle or other means of safe transport.



**WARNING:** Never place fingers in a joint held by an activated tool



**CAUTION:** Never hammer or force the tool into a bolt hole; if it does not fit easily you are using the wrong size of tool.



**CAUTION:** Do not operate the equipment without lubricating all moving parts as in section 7. Use only high pressure molybdenum disulphide grease.

### 3. KIT COMPONENTS

#### SG13TE KIT COMPONENTS

- 1 x SG13TE Tool c/w Hydraulic Cylinder
- 1 x 10,000 psi (700 bar) HP550S Sealed Hand Pump with Gauge
- 1 x 10,000 psi (700 bar) Hydraulic Hose, 2m (78.75")
- 1 x 150 mm (6") Vernier Calliper
- 1 x 1/2" Square Drive Flexible Handle
- 1 x 30 mm (1 1/8") Drive Socket
- 1 x Safety Block
- 2 x M39 (1 1/2") Collets
- 2 x M42 (1 5/8") Collets
- 2 x M45 (1 3/4") Collets
- 1 x Instruction Manual
- 1 x Carry-Case with Protective Foam Inserts



Product Code: SG13TESTD

#### SG15TE KIT COMPONENTS

- 1 x SG15TE Tool c/w Hydraulic Cylinder
- 1 x 10,000 psi (700 bar) HP550S Sealed Hand Pump with Gauge
- 1 x 10,000 psi (700 bar) Hydraulic Hose, 2m (78.75")
- 1 x 300 mm (12") Vernier Calliper
- 1 x 1/2" Square Drive Flexible Handle
- 1 x 36 mm Drive Socket
- 1 x Safety Block
- 2 x M48 (1 7/8") Collets
- 2 x M52 (2") Collets
- 2 x M56 (2 1/4") Collets
- 1 x Instruction Manual
- 1 x Carry-Case with Protective Foam Inserts



Product Code: SG15TESTD

## 4. TECHNICAL DATA

### SG13TE TECHNICAL DATA

#### **Spreading force = 13 T (130 kN) per tool**

It is recommended that tools are used in pairs giving  $2 \times 13 = 26$  T (260 kN)

If using the Equalizer HP550S Hand Pump (or if a hydraulic pressure gauge is fitted), the spreading force per tool can be determined by taking a reading from the gauge. Gauge pressures will produce spreading forces as set out below.

<b>Pressure</b>	<b>Bar</b>	138	276	414	552	690
	<b>psi</b>	2000	4000	6000	8000	10,000
<b>Spreading force</b>	<b>T</b>	2.6	5.2	7.8	10.4	13
	<b>kN</b>	26	52	78	104	130

#### **Spreading distance = 0 - 115mm (0 - 4.53")**

Hydraulic oil grade: 32 centistokes(cSt) @ 40°C tested by ASTM D 445

### SG15TE TECHNICAL DATA

#### **Spreading force = 15 T (150 kN) per tool**

It is recommended that tools are used in pairs giving  $2 \times 15 = 30$  T (300 kN)

If using the Equalizer HP550S Hand Pump (or if a hydraulic pressure gauge is fitted), the spreading force per tool can be determined by taking a reading from the gauge. Gauge pressures will produce spreading forces as set out below.

<b>Pressure</b>	<b>Bar</b>	138	276	414	552	690
	<b>psi</b>	2000	4000	6000	8000	10,000
<b>Spreading force</b>	<b>T</b>	3	6	9	12	15
	<b>kN</b>	30	60	90	120	150

#### **Spreading distance = 0 - 100mm (0 - 3.94")**

Hydraulic oil grade: 32 centistokes(cSt) @ 40°C tested by ASTM D 445



## 5. HOW THE SECURE-GRIP HYDRAULIC TOOLS WORK

- 1.** The two halves of the hydraulic Secure-Grip tool are inserted into opposing flange bolt-holes

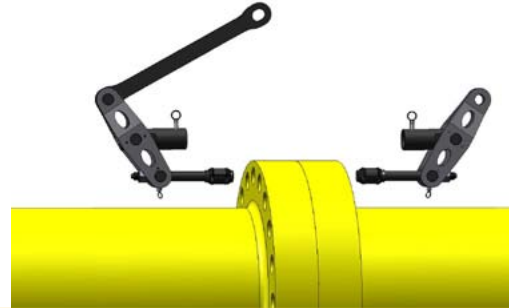

- 2.** Both drive nuts are tightened locking the tool in to the flange bolt-holes

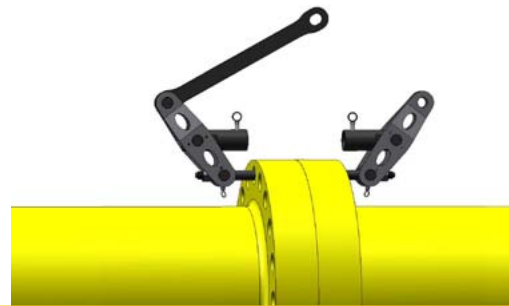

- 3.** The actuator followed by the cantilever are locked into position

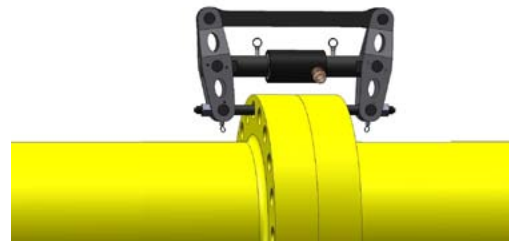

- 4.** The hydraulic hose and hand pump are attached



- 5.** The hand pump is actuated which powers the hydraulics that spread the flange





## 6. INSTALLATION AND OPERATION

### 6.1 COLLET SELECTION BASED ON FLANGE SPECIFICATION



It is important that the correct size of collet is used!  
 An undersized collet could allow the collet holder to pull through its bore!  
 An oversized collet has the potential to become jammed in the bolt-hole!

To select the applicable tool and collet for your flange please refer to the Secure-Grip application charts at the back of this manual (section 12, pages 28-37).

The Secure-Grip hydraulic tools have a range of collets which are applicable to the following bolts and flange bolt-hole diameters:

Collet type	Minimum bolt-hole diameter	Maximum bolt-hole diameter	Metric coarse bolt	UNC bolt	Tool
<b>M39 1 1/2"</b>	38	42	M39	1 1/2"	SG13TE
<b>M42 1 5/8"</b>	41	45	M42	1 5/8"	SG13TE
<b>M45 1 3/4"</b>	44	49	M45	1 3/4"	SG13TE
<b>M48 1 7/8"</b>	47.5	52	M48	1 7/8"	SG15TE
<b>M52 2"</b>	50.5	56	M52	2"	SG15TE
<b>M56 2 1/4"</b>	55.5	62	M56	2 1/4"	SG15TE

If the specification of the flange is unknown then the vernier calliper supplied in the kit should be used to determine the correct collet as shown in section 6.2, pages 8-10.



Important: The Secure-Grip collets are consumable items. The lifespan of a collet will vary depending on the flange materials with which it is used. To increase the lifespan of the collets it is recommended that they are flipped through 180 degrees on the collet holder, this will produce more even wear across the four ridges on the outer profile of the collet. See section 6.3 for details on collet removal and replacement

## 6.2 COLLET SELECTION BASED ON BOLT-HOLE MEASUREMENT



Note: It is important that the vernier calliper is held in the middle of the bolt-hole, and not held at an angle to the flange face, nor used on a bolt-hole which is worn, damaged or distorted, as these actions may result in the selection of an incorrect size of collet

1. To ensure a true measurement is taken, hold the vernier calliper:
  - square to the flange face
  - in the middle of the bolt-hole

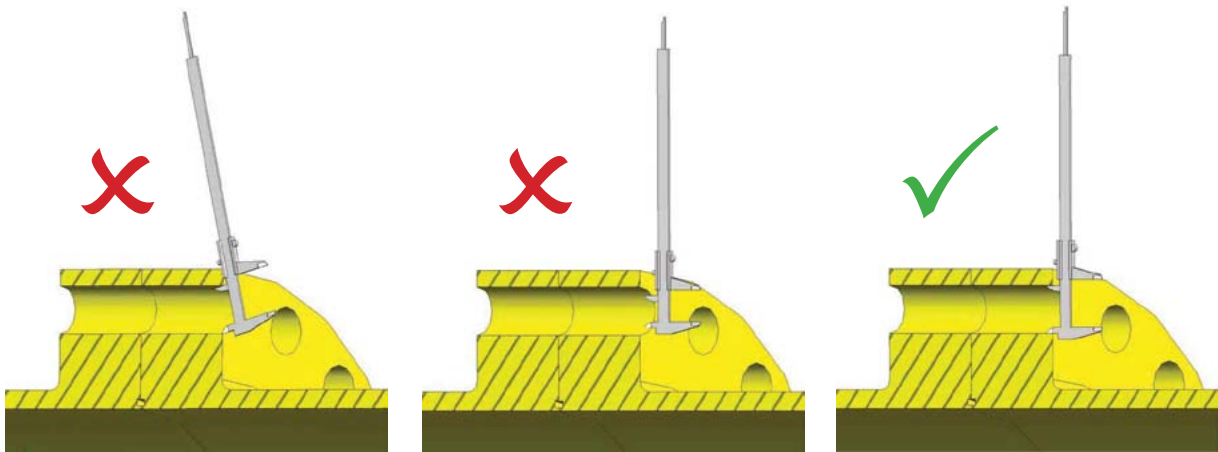

2. To determine whether the bolt-hole is round, take two separate measurements with the vernier calliper turned through 90° between measurements

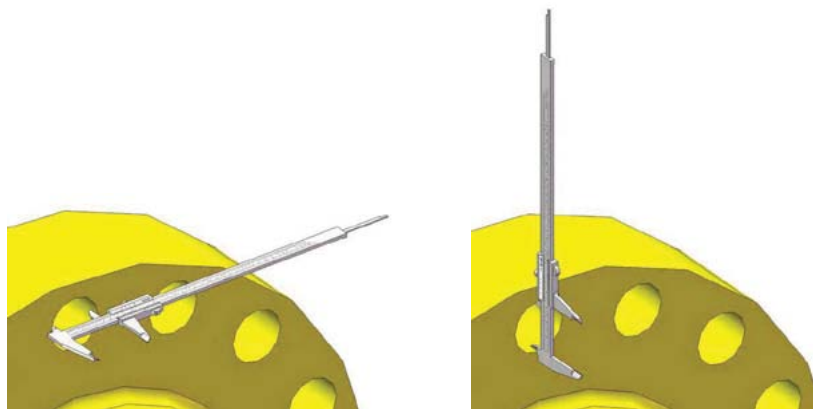

- 3.** To read the measurement from the vernier calliper, scan along the desired scale from left to right. In this example, the major figure is 60mm, this is added to the minor figure of 8mm (indicated by where the vernier scale aligns with the main scale), giving a total measurement of 68mm.

With a bolt-hole size of 68mm, the operator can determine which collet and tool is appropriate to this flange by referring to the Secure-Grip Tool Range chart in section 11, page 27. For example: 68mm falls within the 63mm minimum and 69mm maximum bolt-hole sizes. Therefore collet identification is M64 / 2½" and the tool to be used is the SG18TE.

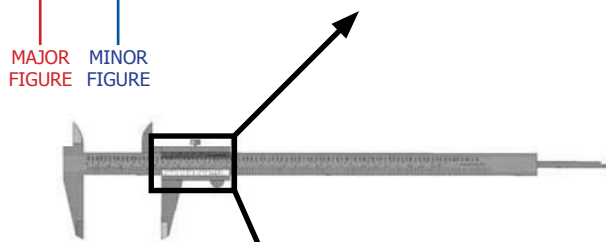
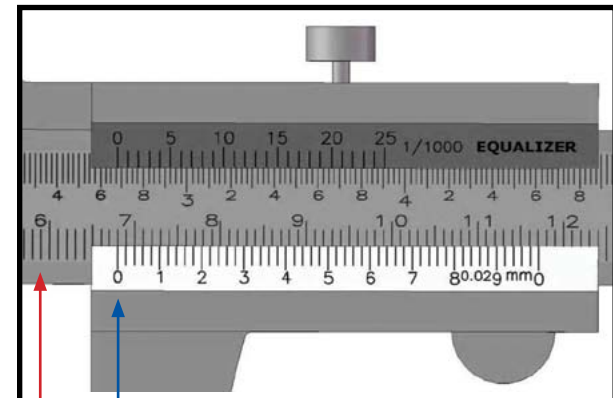

- 4.** If the measurement contains fractions of a millimetre the method of reading the vernier calliper is slightly different. In this example, the major figure is 40mm (read in the same way as previously described). The minor figure is 7mm (read to the left of the zero). The fraction is 0.5mm (read from where the vernier scale lines up with the main scale). This gives a total measurement of 47.5mm.

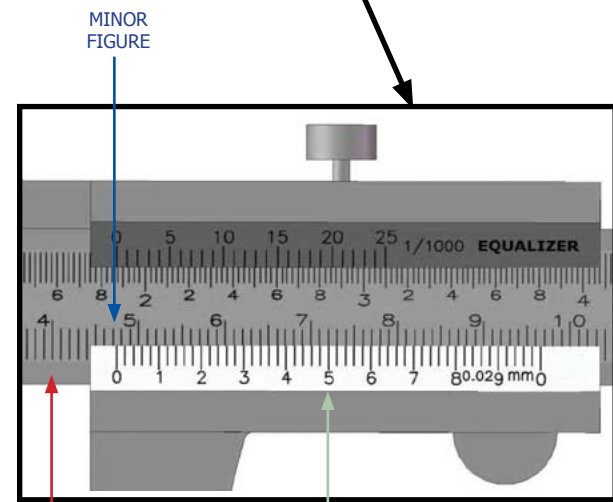

- 6.** Each tool in the Secure-Grip range comes with the appropriate sizes of collets for that tool. If the collet labelling is worn or missing then the collet can be measured to ensure that the correct size is selected. An accurate measurement can only be obtained with the collet mounted on the collet holder. To do this:
- remove the collet head assembly from the tool and disassemble (see section 6.3, page 11 for details)
  - slide the collet over the collet holder
  - measure the centre section of the collet with the vernier calliper
  - identify the collet using the chart below, and select the correct size for the flange

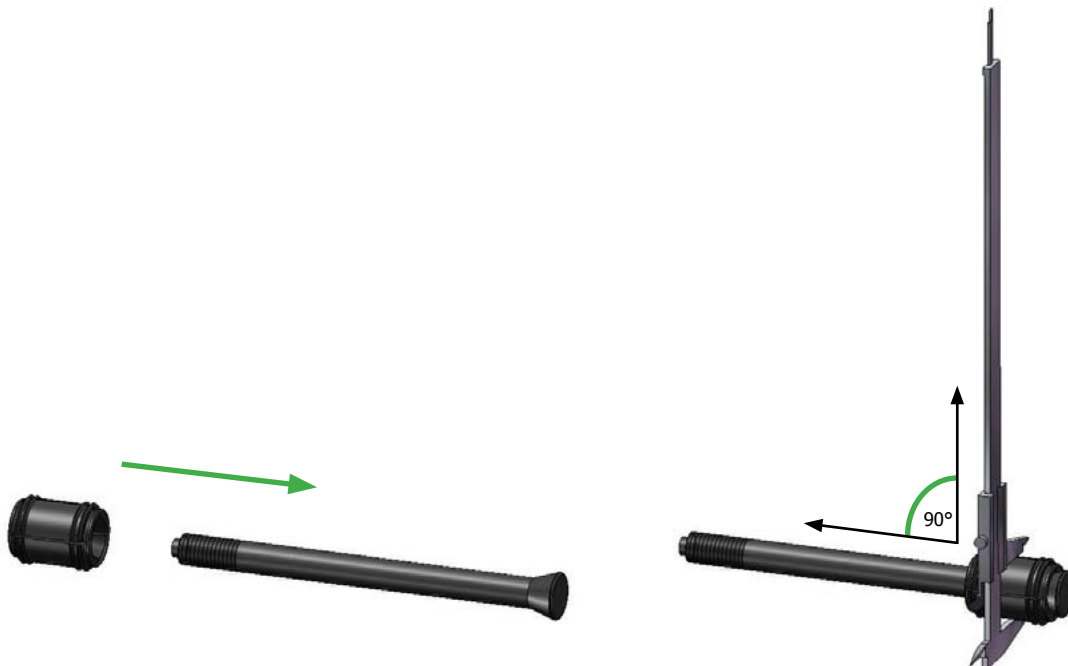

Centre section Ø	Collet type	Min. bolt-hole Ø	Max. bolt-hole Ø	Metric coarse bolt	UNC bolt
36mm	<b>M39 1 1/2"</b>	38mm	42mm	M39	1 1/2"
39mm	<b>M42 1 5/8"</b>	41mm	45mm	M42	1 5/8"
40.5mm	<b>M45 1 3/4"</b>	44mm	49mm	M45	1 3/4"
44.5mm	<b>M48 1 7/8"</b>	47.5mm	52mm	M48	1 7/8"
47.5mm	<b>M52 2"</b>	50.5mm	56mm	M52	2"
52.5mm	<b>M56 2 1/4"</b>	55.5mm	62mm	M56	2 1/4"

## 6.3 COLLET REMOVAL AND REPLACEMENT

Once the correct collet has been selected it may be necessary to change the collet on the tool:

1. Place the tool on its side on a work bench or flat surface and unscrew and remove the drive nut

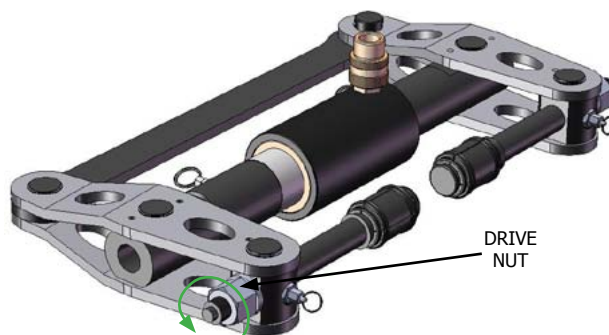

2. Pull the collet spring plunger ring out, and remove the collet head assembly from the tool

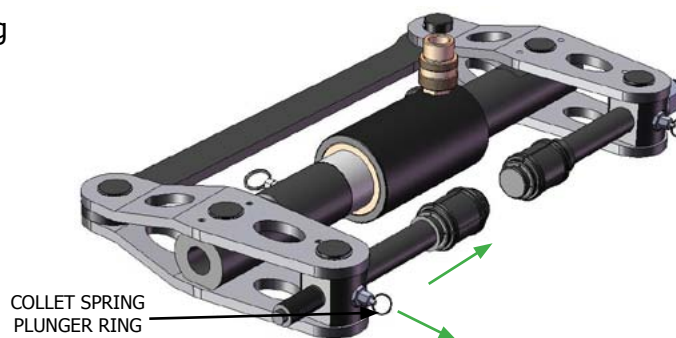

3. Slip the drive tube and drive cone off the collet holder



4. Remove the collet from the collet holder and replace it with the correct collet for the flange to be separated



5. Reverse the above procedure to re-assemble the tool. Care should be taken to ensure the slot in the collet holder is aligned with the collet spring plunger

## 6.4 STANDARD INSTALLATION AND OPERATION

Once the correct collet has been selected and mounted, tool operation can commence



Before attaching the tool ensure at least two flange bolts remain in place 180 degrees apart with nuts loosened sufficiently enough for flange work to be carried out. These bolts will reduce lateral flange movement during flange spreading.

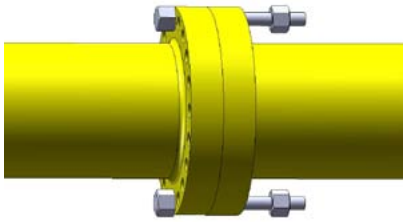

1. Before installation can begin the tool must be dismantled into three parts

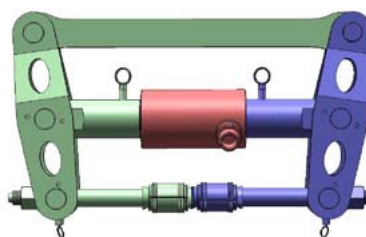

2. Lay the tool on a flat surface. Pull the cantilever pin out and rotate the cantilever out of position.

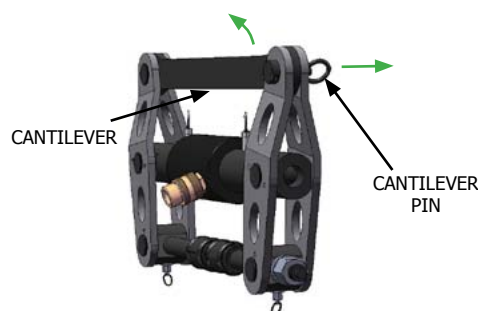

3. Pull on the left hand actuator spring plunger and pull the actuator from the actuator to leg connector. Repeat this on the right hand side

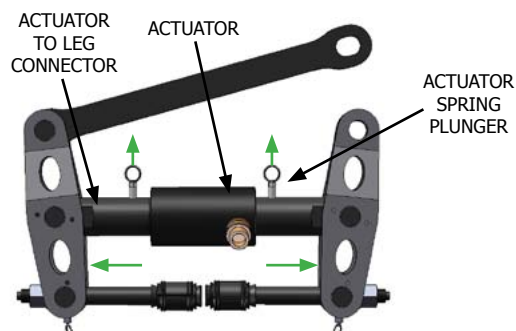

4. The tool should now be in three parts - two halves and the actuator

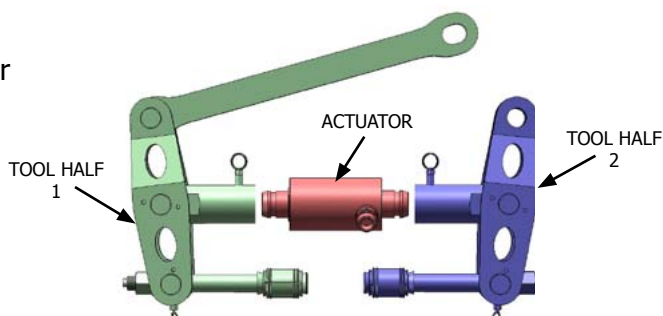



- 5.** Measure the thickness of the flange using the vernier calliper provided. Lock the calliper in position by tightening the locking screw

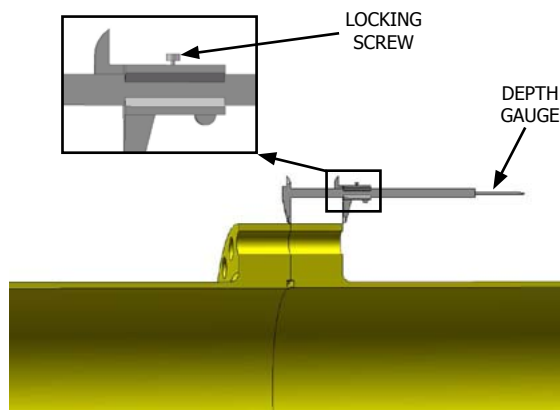

- 6.** Select a suitable bolt-hole in which to attach the tool. Insert the depth gauge part of the vernier calliper into the bolt hole keeping the base of the calliper flush with the bolting face of the flange

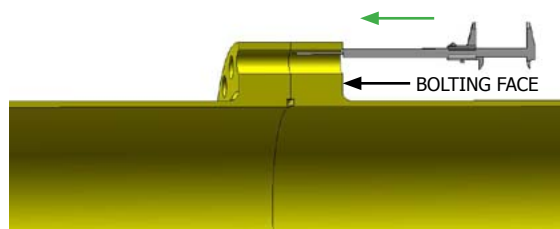

- 7.** Insert the collet on the first half of the tool into the the opposite end of the same bolt-hole until it touches the end of the depth gauge (so that the collet is fully through one flange but not entering the other)

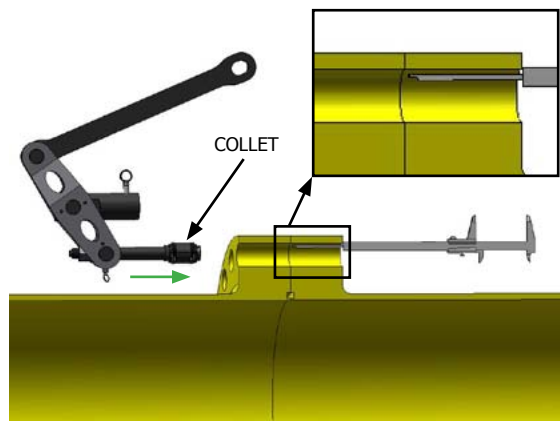

- 8.** Tighten the drive nut with the 1/2" square drive flexible handle. The first half of the tool will now have a secure hold in the bolt-hole

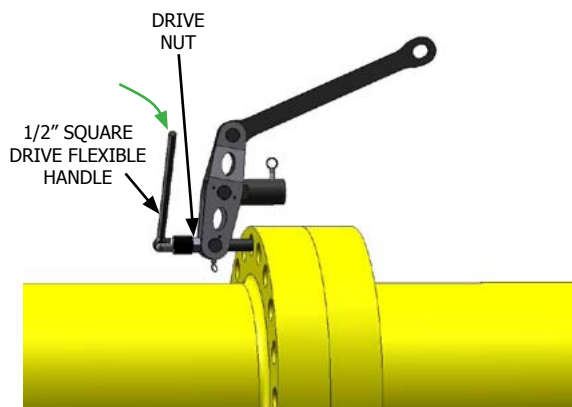





- 9.** Insert the collet on the second half of the tool in to the bolt-hole until it touches the collet on the first half of the tool, and tighten the drive nut using the 1/2" square drive flexible handle. The second half of the tool will now have a secure hold in the bolt-hole

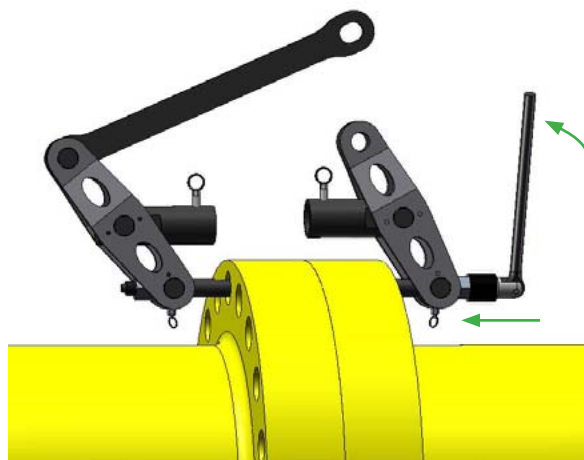

- 10.** Insert one side of the actuator into each 'actuator to leg connector'. On both sides push the actuator until you feel the actuator spring plunger click.

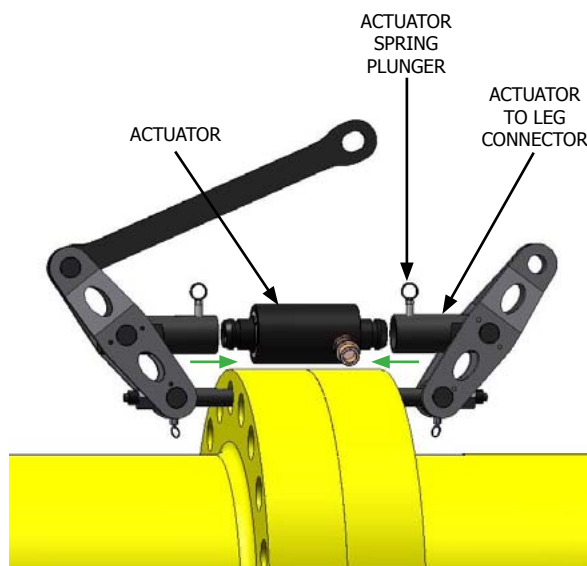

- 11.** Rotate the cantilever into position, and secure by sliding the cantilever pin (through the hole at the top of the leg and the hole in the cantilever) until fully home

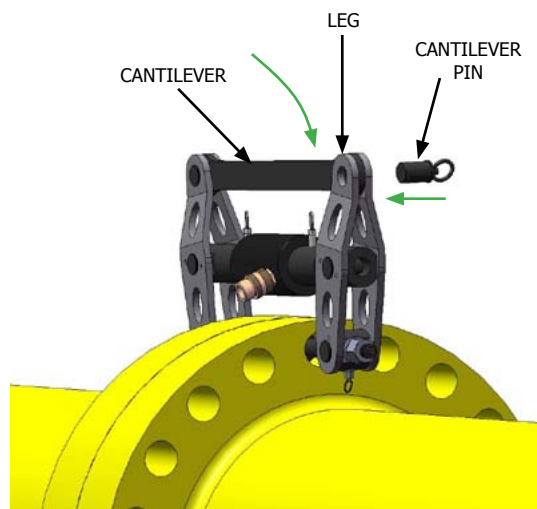



- 12.** Select the bolt-hole 180° opposite the tool you have just attached and repeat steps 2 to 7 for the second tool



Note: If more than two tools are being used they should be attached at an equal spacing around the flange joint

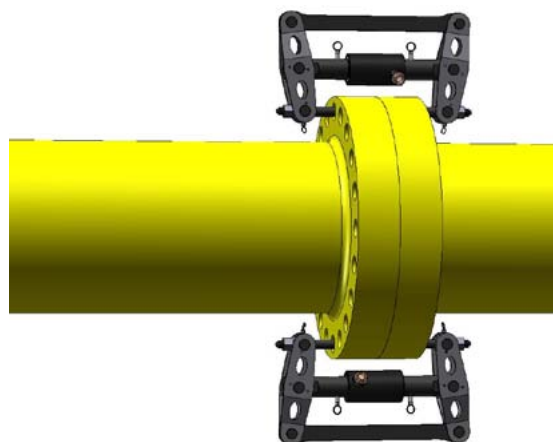

- 13.** Connect the hand pumps to the hydraulic hoses, and the hydraulic hoses to the actuators on each tool. Ensure that all couplers are fully hand tightened and the release valves are closed hand tight

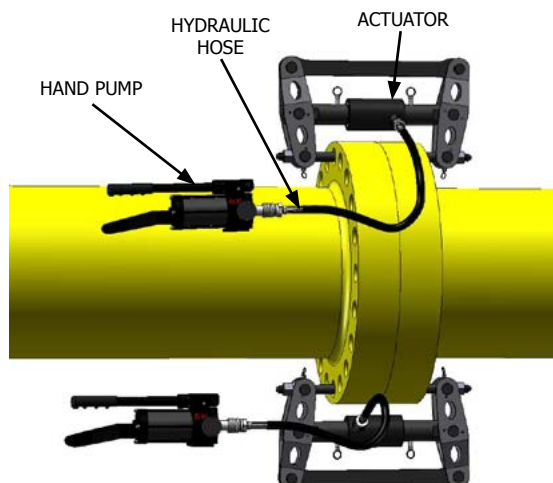

- 14.** Flange spreading can now begin. Give the first tool four strokes on the hand pump, then give the same to the second. As the flange is separating, measure the gap at both tools, and if necessary adjust the number of strokes on one side to ensure the flange faces are kept parallel.



**WARNING:** Never place fingers in a joint held by an activated tool

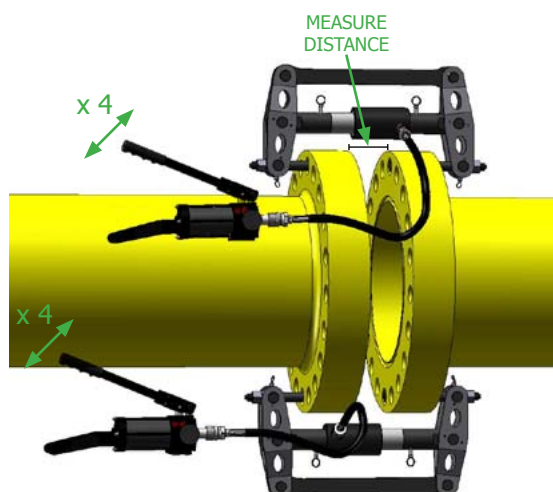

- 15.** Continue spreading the flange until the access gap required is achieved, or until the maximum pressure or tool travel has been reached. If the flange does not spread refer to section 10

Tool type	Max. distance
SG13TE	115mm (4.53")
SG15TE	100mm (3.94")

Pressure	Bar	138	276	414	552	690
	psi	2000	4000	6000	8000	10,000
<b>SG13TE spreading force</b>	T	2.6	5.2	7.8	10.4	13
<b>SG15TE spreading force</b>	T	3	6	9	12	15

- 16.** Once the flange has been separated and prior to any maintenance works the safety blocks must be inserted between the flanges. These are held in position by replacing two of the flange bolts.

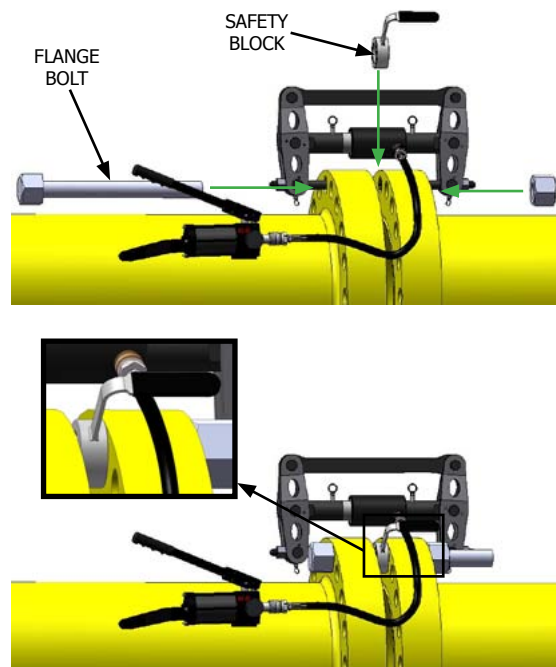

- 17.** Following any maintenance works and prior to closing the flange joint, the safety block must be removed. The release valves on the hand pumps should now be turned anti-clockwise gently and evenly, adjusting as necessary to keep the flanges parallel until the flange is fully closed and there is no load on the tools. The tools can then be removed by reversing the installation procedure (steps 7 - 13)

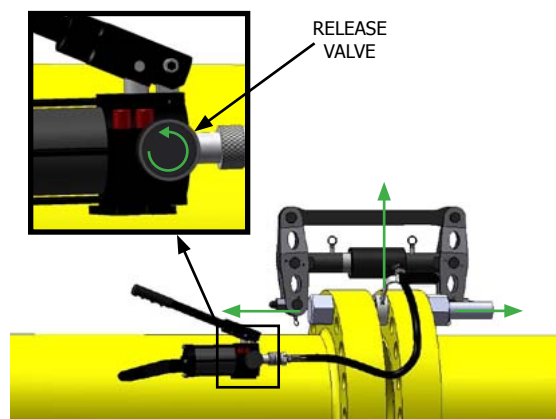



## 6.5 RESTRICTED ACCESS INSTALLATION AND OPERATION

The Secure-Grip hydraulic tools are also ideal for use where access to the flange is restricted. As in the standard operation, two tools should be used in order to avoid flange distortion, with the tools positioned 180° from each other on the flange.

Before beginning the following procedure, complete steps 1 - 4 of the standard installation procedure (see section 6.4, pages 12-16)

- 1.** On one half of the tool unscrew and remove the drive nut. Pull the collet spring plunger ring out, and remove the collet head assembly from the tool

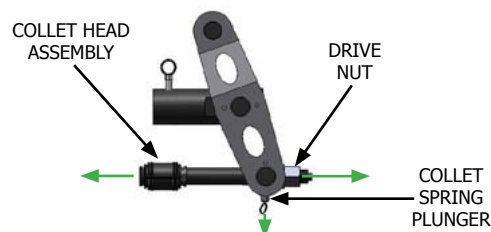

- 2.** Pass the collet head assembly through both bolt-holes from the open access side

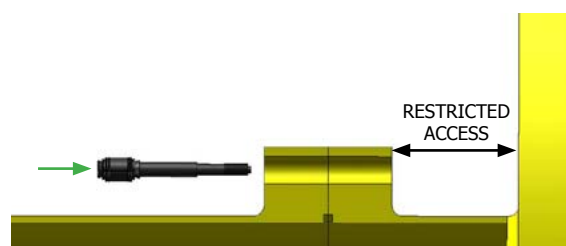

- 3.** Refit the tool half on to the collet holder

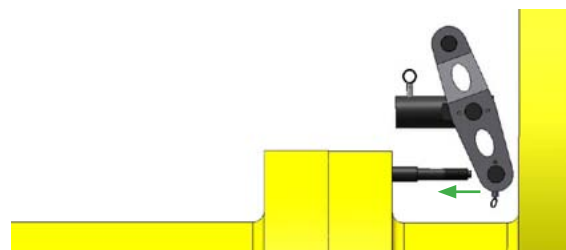

- 4.** Refit the drive nut

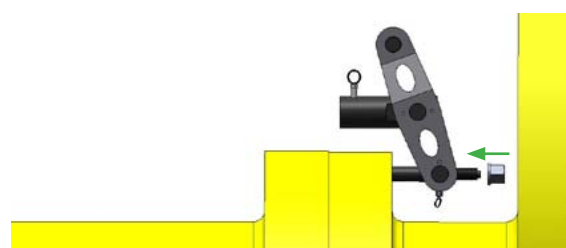

- 5.** Measure the thickness of the flange with the vernier calliper provided and using the vernier calliper as a depth gauge, adjust the position of the collet until it touches the end of the depth gauge (so that the collet is fully through one flange but not entering the other)

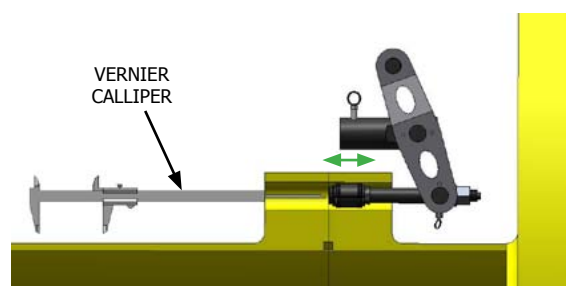

The procedure can now be completed by following steps 8 - 17 of the standard installation procedure (see section 6.4, pages 12-16)

## 6.6 VALVE, SPADE OR BLIND REMOVAL, INSTALLATION AND OPERATION

The Secure-Grip hydraulic tools are also ideal for the removal and insertion of blinds, spades and valves. Equalizer International can supply a short collet holder kit that will increase the relative stroke of the tool.

TOOL	collet holder	C min	C Max
<b>SG13TE</b>	standard	0mm (0")	115mm (4.5")
<b>SG13TE</b>	short	60mm (2.36")	175mm (6.89")
<b>SG15TE</b>	standard	0mm (0")	100mm (3.9")
<b>SG15TE</b>	short	80mm (3.15")	180mm (7.09")

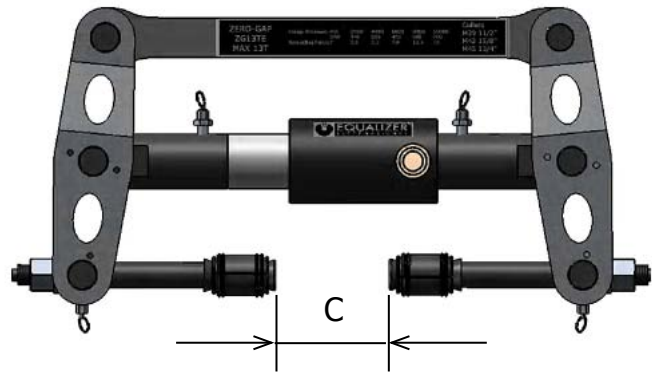

1. please refer to section 6.3 notes 1-4 for instruction on how to remove the standard collet holder and drive tube. These are then replaced with the short collet holders and short drive tube with the appropriate collet.



2. Please follow section 6.4 for instruction on how to attach and activated the secure-grip hydraulic tool.

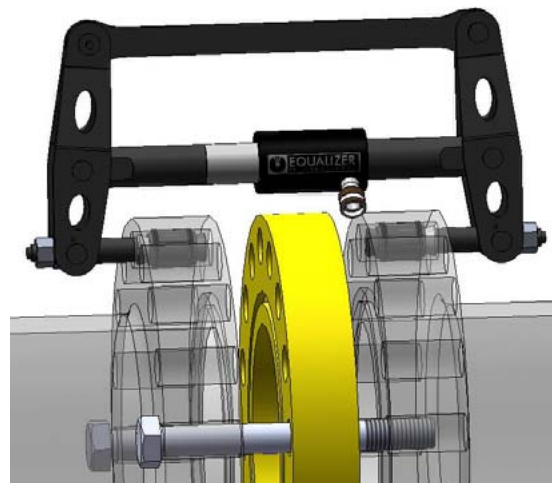
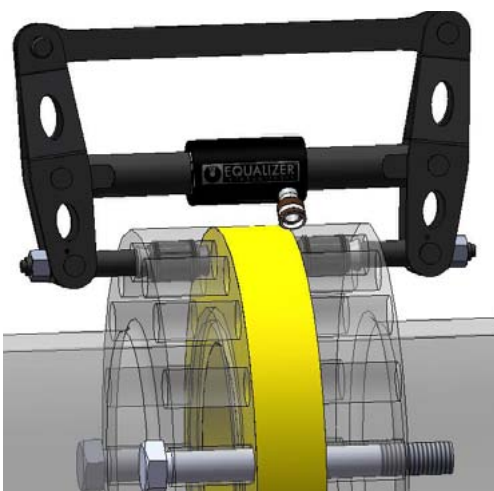

## 7. MAINTENANCE AND LUBRICATION

On return from each job and before allocation against subsequent work the completeness of the Equalizer Secure-Grip hydraulic tool kits must be established and items examined to ensure that they are serviceable.

At regular intervals and specifically after exposure to salt water Secure-Grip hydraulic tools should be dismantled and lubricated as follows:

1. Lay the tool on a bench or flat surface



2. Remove the cantilever pin and remove the collet union, actuator connector and cantilever retaining rings. Care should be taken not to over stretch the retaining rings during removal or replacement

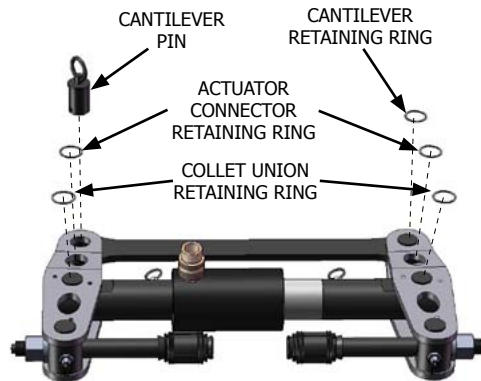

3. Lift the top leg on both sides from the tool

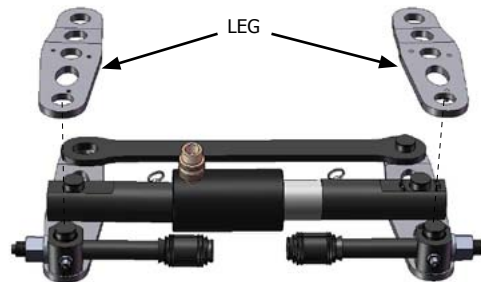

4. Lift the actuator assembly and the cantilever from the tool

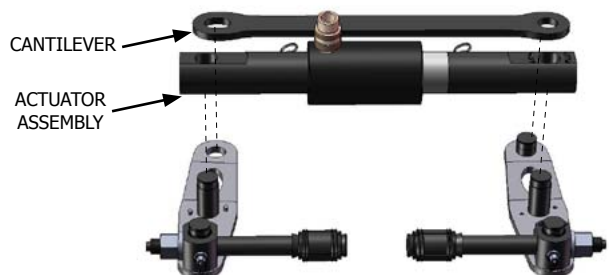





- 5.** The exposed parts of the tool can now be cleaned and lubricated. Care should be taken to ensure the centring springs do not jump out of their recess

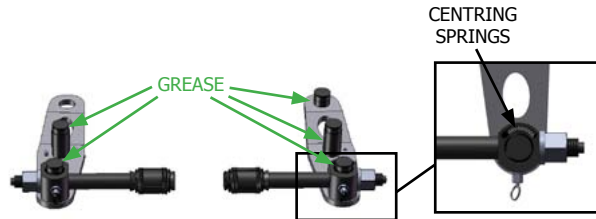

Note: it is recommended that the tool is wiped down with a clean rag and WD40 or similar cleaning fluid to remove any dirt or grit and then liberally greased with a high load bearing grease (Rocol sapphire high load 2 or similar) in the areas shown

- 6.** The tool can now be reassembled by reversing the dismantling procedure



Note: care should be taken to ensure the dowel protruding from the right hand leg of the tool is engaged between the two centring springs

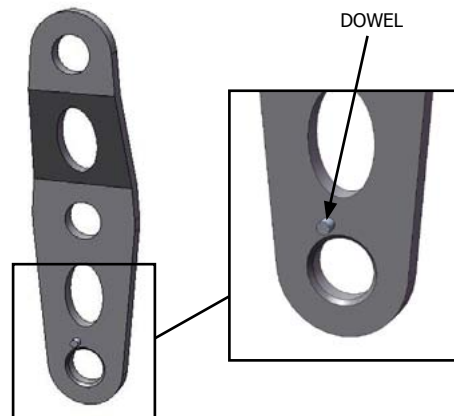

- 7.** Once the tool is rebuilt, flip the tool over and repeat the above procedure with the other side of the tool



Note: if the actuator requires maintenance please refer to an authorised Equalizer distributor



## 8. PARTS LISTS

### SG13TE PARTS LIST

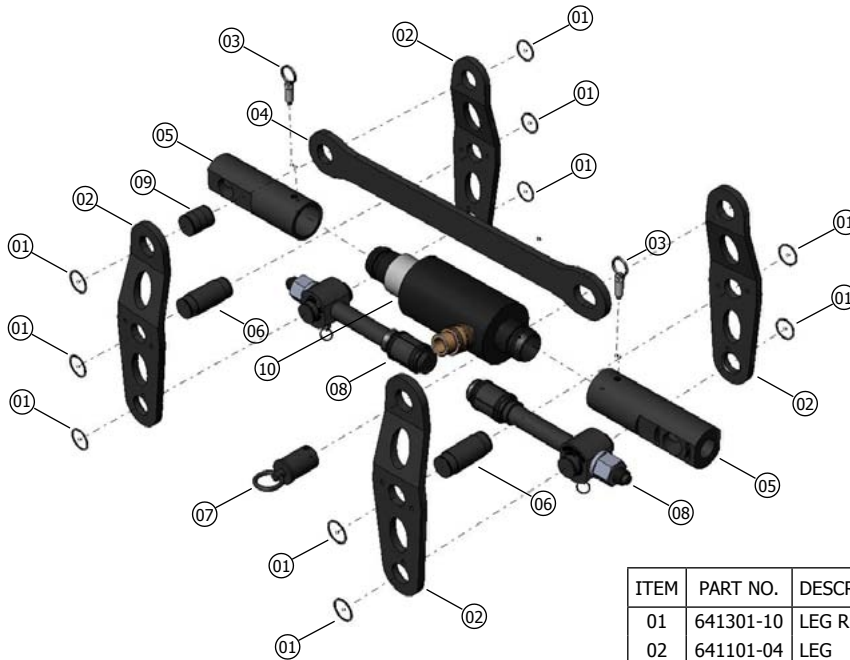

ITEM	PART NO.	DESCRIPTION	QUANTITY
01	641301-10	LEG RETAINING RING	10
02	641101-04	LEG	04
03	900502-02	M10 SPRING PLUNGER	02
04	641501-01	CANTILEVER	01
05	641901-02	ACTUATOR UNION	02
06	641401-02	ACTUATOR PIN	02
07	641701-01	PULL PIN	01
08		SEE COLLET HEAD PARTS LIST	
09	643201-01	CANTILEVER PIN	01
10	644001-01	ACTUATOR ASSEMBLY	01

### COLLET HEAD PARTS LIST

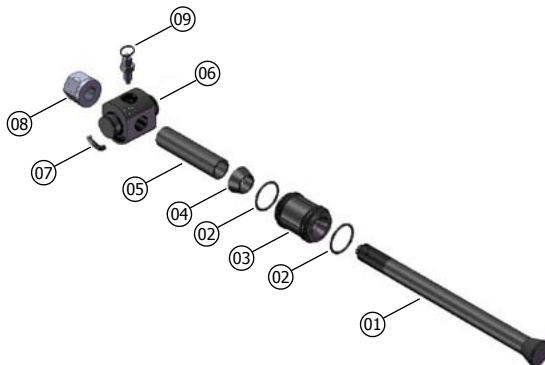

ITEM	PART NO.	DESCRIPTION	QUANTITY
01	640401-02	COLLET HOLDER	01
02	642201-04	M39 SPRING RING	04
	642401-04	M42 SPRING RING	04
	642601-04	M45 SPRING RING	04
03	640101-02	M39 COLLET	02
	640201-02	M42 COLLET	02
	640301-02	M45 COLLET	02
04	640501-02	DRIVE CONE	02
05	641601-02	DRIVE TUBE	02
06	640601-02	COLLET UNION	02
07	402201-02	CENTRING SPRING 1	02
08	640901-02	COLLET NUT	02
09	641001-02	M12 SPRING PLUNGER	02



## SG15TE PARTS LIST

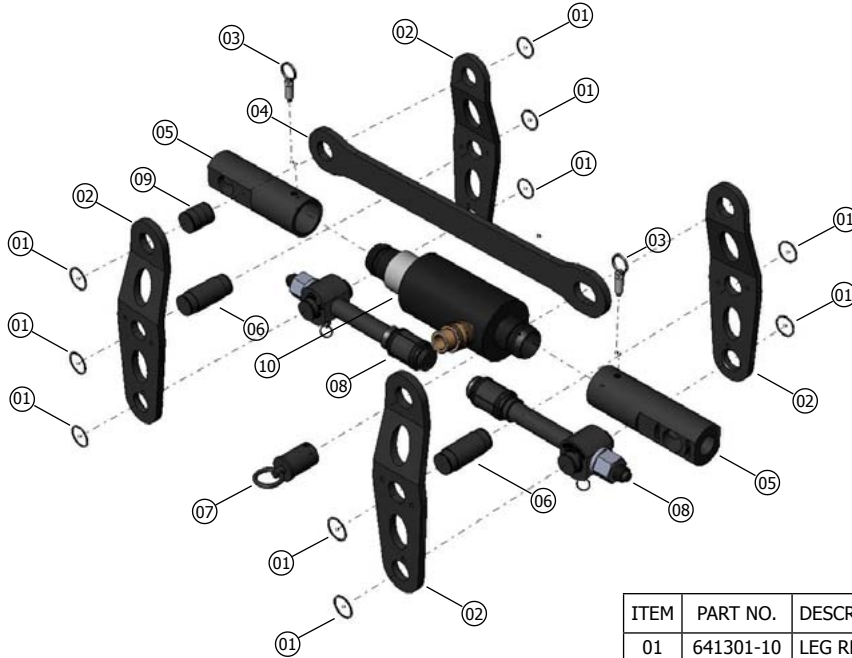

ITEM	PART NO.	DESCRIPTION	QUANTITY
01	641301-10	LEG RETAINING RING	10
02	651101-04	LEG	04
03	900502-02	M10 SPRING PLUNGER	02
04	651501-01	CANTILEVER	01
05	651901-02	ACTUATOR UNION	02
06	651401-02	ACTUATOR PIN	02
07	641701-01	PULL PIN	01
08		SEE COLLET HEAD PARTS LIST	
09	643201-01	CANTILEVER PIN	01
10	644001-01	ACTUATOR ASSEMBLY	01

## COLLET HEAD PARTS LIST

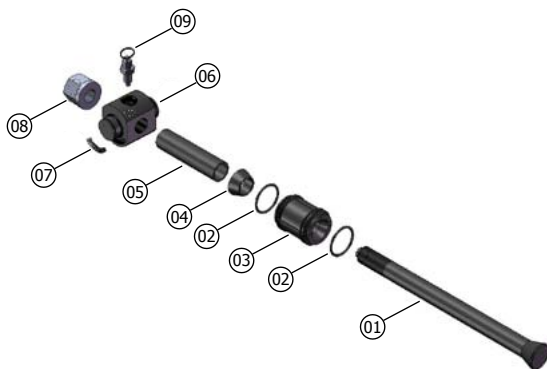

ITEM	PART NO.	DESCRIPTION	QUANTITY
01	650401-01	COLLET HOLDER	01
02	652201-04	M48 SPRING RING	04
	652401-04	M52 SPRING RING	04
	652601-04	M56 SPRING RING	04
03	650101-02	M48 COLLET	02
	650201-02	M52 COLLET	02
	650301-02	M56 COLLET	02
04	650501-02	DRIVE CONE	02
05	651601-02	DRIVE TUBE	02
06	650601-02	COLLET UNION	02
07	402201-02	CENTRING SPRING 1	02
08	650901-02	COLLET NUT	02
09	641001-02	COLLET SPRING PLUNGER	02

## HP550S PARTS LIST

ITEM	PART No.	DESCRIPTION	KIT QUANTITY	PUMP QUANTITY
01	710101-01	<b>PUMP HOUSING</b>		01
02	730601-01	<b>RESERVOIR</b>		01
	715300-01	<b>SERVICE KIT C:</b>		
03		- O-RING	01	01
04		- BACK-UP RING	01	01
05		- H.P. PISTON	01	01
06		- SNAP RING	01	01
07		- O-RING	01	01
08		- BACK-UP RING	01	01
09		- L.P. PISTON	01	01
10	715500-01	<b>SERVICE KIT E:</b>		
11		- YOKE BASE	01	01
		- SPRING PIN	01	01
12	715600-01	<b>SERVICE KIT F:</b>		
13		- SEAL	01	01
14		- WASHER	01	01
		- RELEASE VALVE	01	01
15		SCREW	01	01
16		- SCREW	01	01
17		- RELEASE KNOB	01	01
37		- COUPLERS	01	01
		- CHECK BALL	01	01
18	715700-01	<b>SERVICE KIT G:</b>		
19		- SPRING	02	02
20		- STEEL BALL	02	02
21		- OUTLET BALL SPRING	02	02
22		- COPPER WASHER	02	02
23		- VALVE COVER SCREW	02	02
		- STEEL BALL	02	02
24	715800-01	<b>SERVICE KIT H:</b>		
25		- STEEL BALL	01	01
26		- SPRING END CAP	01	01
27		- L.P. SPRING	01	01
28		- O-RING	02	02
		- OVERLOAD COVER	01	01
29		SCREW	02	02
30		- CAP	01	01
31		- CONE SEAT	01	01
32		- CONE	01	01
		- LONG SEPARATOR	01	01
33		SPRING		
		- OVERLOAD COVER	01	01
34	715900-01	<b>SERVICE KIT I:</b>		
35		- BASE PLATE	01	01
		- SCREW	02	02
36	716100-01	<b>SERVICE KIT K:</b>		
37		- SCREW	04	03
38		- CHECK BALL	04	03
54		- SCREW	01	01
		- SCREW	01	01
39	716200-01	<b>SERVICE KIT L:</b>		
40		- GAUGE COUPLER	01	01
		MALE		
		- GAUGE	01	01

ITEM	PART No.	DESCRIPTION	KIT QUANTITY	PUMP QUANTITY
41	716300-01	<b>SERVICE KIT M:</b>		
42		- GAUGE COUPLER	01	01
43		FEMALE	01	01
		- COUPLER	01	01
		- PORT GAUGE	01	01
		ADAPTOR		
44	735100-01	<b>SERVICE KIT N:</b>		
45		- RESERVOIR BLADDER	01	01
46		- OIL FILTER	01	01
47		- O-RING	01	01
		- REFILLING PLUG	01	01
48	735300-01	<b>SERVICE KIT O:</b>		
49		- HANDLE	01	01
50		- YOKE	01	01
51		- PISTON PIN	01	01
52		- YOKE PIN	01	01
53		- RETAINING RING	01	01
54		- HANDLE GRIP	01	01
		- SCREW	01	01
55	735200-01	<b>SERVICE KIT P:</b>		
56		- SCREW	04	04
57		- TAIL BASE	01	01
58		- SPRING WASHER	04	04
		- NUT	04	04

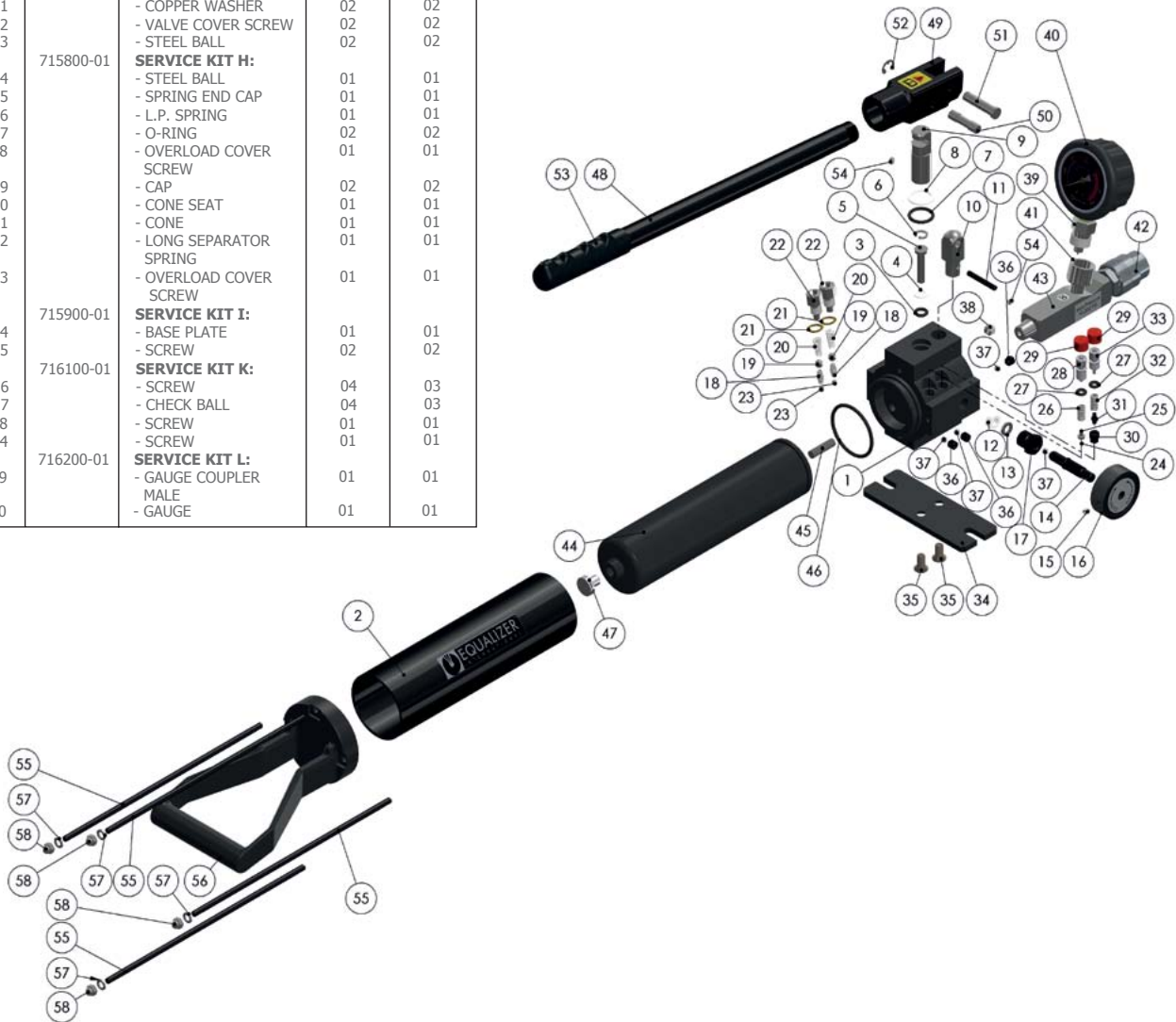

## 9. WEIGHTS AND DIMENSIONS

### CLOSED TOOL DIMENSIONS

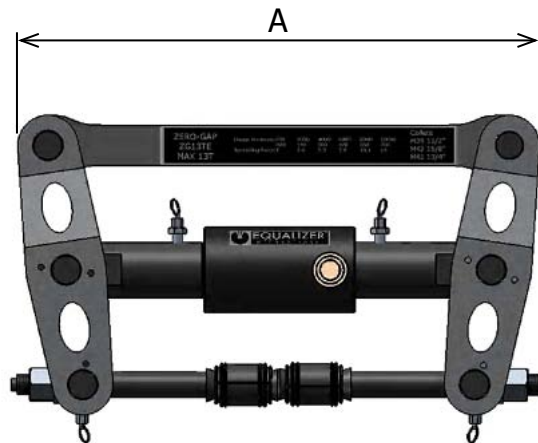

### OPEN TOOL DIMENSIONS

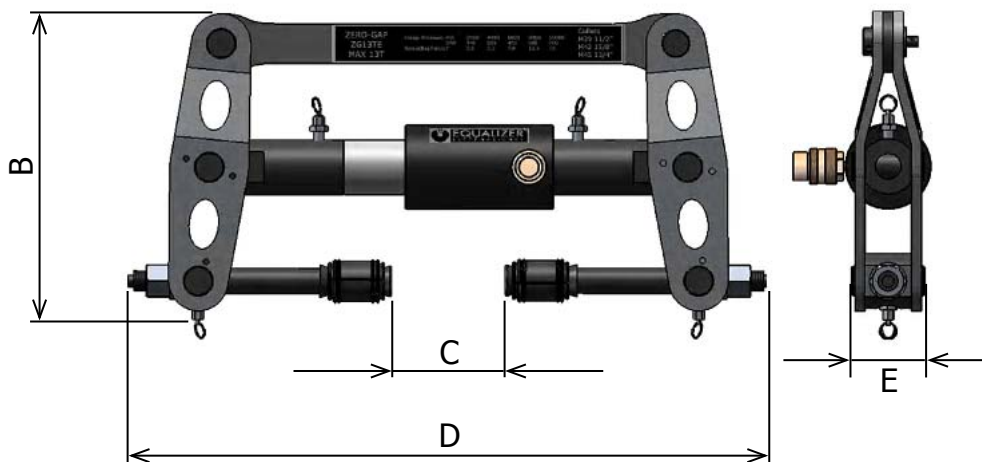

TOOL	A	B	C	D	E	TOOL WEIGHT	KIT WEIGHT
<b>SG13TE</b>	516mm (20.3")	314mm (12.4")	115mm (4.5")	630mm (24.8")	72mm (2.9")	21.5kg (47.3lbs)	40.5kg (89.2lbs)
<b>SG15TE</b>	600mm (23.6")	380mm (15.0")	100mm (3.9")	720mm (28.4")	80mm (3.2")	26kg (57.3lbs)	45kg (99.2lbs)

## 10. TROUBLESHOOTING

**Problem:** Hoses are connected but the tool does not advance. The pressure on the pump handle is minimal.

- The release valve is in the retract (open) position → Close the release valve



**Problem:** Hoses are connected and the pump quickly reaches maximum pressure but the tool has not advanced

- One or more of the connectors are not fully tightened and the hydraulic oil cannot pass through from the pump to the cylinder → Check all connectors are fully tightened and the release valve is in the fully closed position

**Problem:** Hoses are connected and the tool advances with maximum pressure on the pump handle but the joint will not spread

- The pressure required to spread the joint is greater than that of the two tools you are using → Add another one or two tools and distribute them equally around the joint (120° apart with 3 tools and 90° apart with 4 tools) and try again

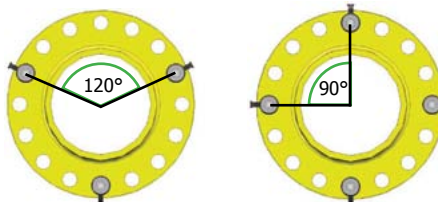

**Problem:** Hoses are connected and the tool advances but there is minimal pressure on the pump handle and the handle is rising back of its own accord

- There is dirt or a damaged valve seat within the pump unit → The pump should be sent to an authorised Equalizer distributor for repair



**Problem:** Hoses are connected and the tool advances as the pump is primed but the pressure on the pump handle is minimal and feels spongy

→ Air could be present in the hydraulic system

→ Use the airlock removal procedure as follows:

1. Connect the hand pump to the tool with the hydraulic hose
2. Close the release valve on the pump, and prime the pump until the hydraulic cylinder is fully extended and a small pressure is achieved
3. With the hand pump held above the tool and the tool in an upright position, open the release valve causing any air that is within the system to be forced up through the pump and vented into the oil reservoir
4. Repeat steps 1 - 3 three or four times to ensure that all air is removed from the system and the tool will reach full working pressure
5. Disconnect the hand pump from the hydraulic hose, grip the baseplate of the hand pump body in a vice with the pump body vertical and the main handle at the top
6. Remove the four nuts holding the main handle and lift off
7. Grip the refilling plug with pliers and extract it by pulling and twisting simultaneously. Ensure the reservoir body is held down when removing the refilling plug as pulling up on the reservoir body will release the bladder within, and oil will spill out.
8. Fill the reservoir to the top with a good quality hydraulic oil of the grade 32 cSt
9. Reinsert the refilling plug, wipe away any oil, and reassemble by reversing the disassembly process





**Problem: One collet is jammed in a bolt-hole**

↳ A collet which is too small or large has been selected, or the collet has been inserted into a damaged or non-round bolt-hole

↳ Removal can be achieved as follows:

1. Pull the collet spring plunger ring out, and remove the rest of the tool, leaving the collet head assembly in the bolt hole
2. Unscrew the drive nut and remove the drive cone and collet cone
3. Screw the drive nut back onto the collet holder until it is 1-2mm off the end
4. Using a hammer and a suitable drift, move the collet holder until the drive nut is against the flange
5. Remove the drive nut and push the collet holder through the flange and out of the other end of the bolt-hole
6. Drive the collet out using the collet holder

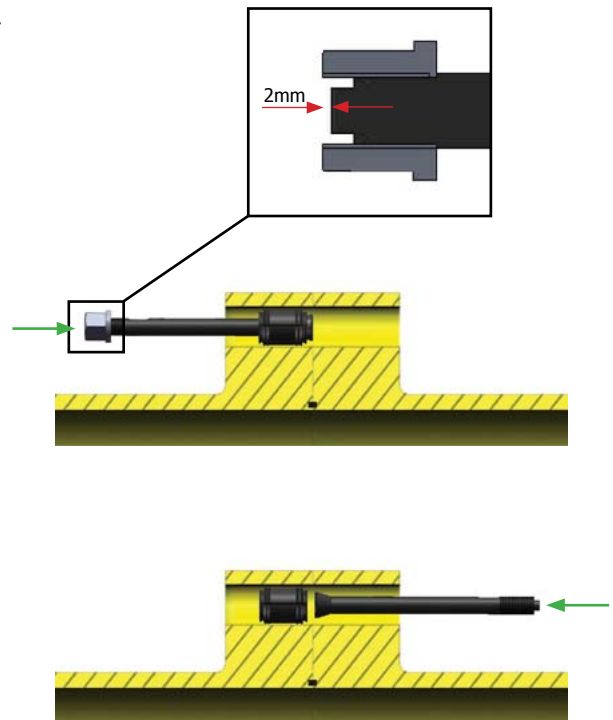





Problem: A pair of collets are jammed in a bolt-hole

→ A collet which is too small or large has been selected, or the collet has been inserted into a damaged or non-round bolt-hole

→ The flange must be spread before removal can be attempted. This can be done using another pair of Secure-Grip tools, or another method if available. Removal can then be achieved as follows:

1. On both sides, pull the collet spring plunger ring out, and remove the rest of the tool, leaving the collet head assemblies in the bolt-hole
2. On both sides, unscrew the drive nut and remove the drive cone and collet cone
3. On the left-hand side, screw the drive nut back onto the collet holder until it is 1-2mm off the end

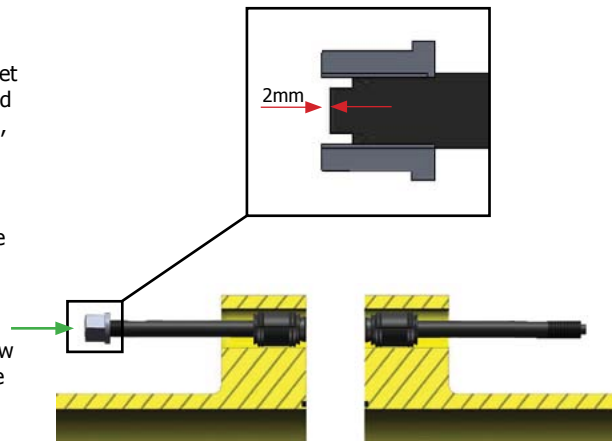

4. Using a hammer and a suitable drift, move the collet holder until it is possible to cut off the tapered end of the collet holder
5. Cut off the tapered end with a hack saw or other cutting tool
6. Withdraw the collet holder from the bolt-hole

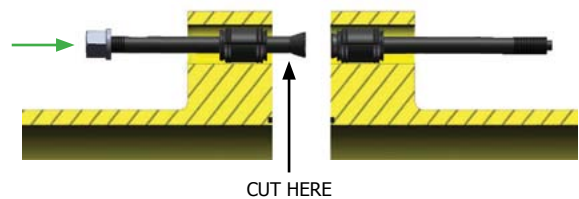

7. Using a hammer and a suitable drift, move the collet holder on the right-hand side up to the left-hand side collet and drive it out
8. Drive the right-hand side collet out using the collet holder

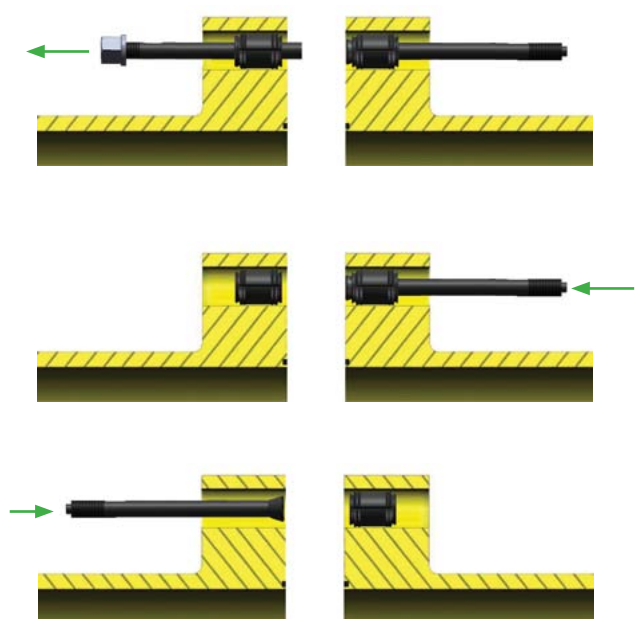

## 11. SECURE-GRIP TOOL RANGE

Collet identification	Tool type	Operation type	SWL (ton)	Min. bolt-hole diameter	Max. bolt-hole diameter
M16 5/8"	SG4TM	manual	4	17.5	19.5
M20 3/4"	SG4TM	manual	4	20.5	23
M24 7/8"	SG6TM	manual	6	24	26.5
M27 1"	SG6TM	manual	6	27.5	30
M30 1 1/8"	SG11TM	manual	11	30	33
M33 1 1/4"	SG11TM	manual	11	32	36
M36 1 3/8"	SG11TM	manual	11	35	39
M39 1 1/2"	SG13TE	hydraulic	13	38	42
M42 1 5/8"	SG13TE	hydraulic	13	41	45
M45 1 3/4"	SG13TE	hydraulic	13	44	49
M48 1 7/8"	SG15TE	hydraulic	15	47.5	52
M52 2"	SG15TE	hydraulic	15	50.5	56
M56 2 1/4"	SG15TE	hydraulic	15	55.5	62
M60	SG18TE	in-line hydraulic	18	59.5	63
M64 2 1/2"	SG18TE	in-line hydraulic	18	63	69
M70 2 3/4"	SG18TE	in-line hydraulic	18	69	75
M76 3"	SG25TE	in-line hydraulic	25	75	81
M80 3 1/4"	SG25TE	in-line hydraulic	25	79	86
M84	SG25TE	in-line hydraulic	25	83	88
M90 3 1/2"	SG25TE	in-line hydraulic	25	88	94
M95 3 3/4"	SG25TE	in-line hydraulic	25	94	101
M100 4"	SG25TE	in-line hydraulic	25	99	107

## 12. RANGE OF APPLICATION CHARTS

Use the charts on the following pages to determine which Secure-Grip tool (and which collet size) is suitable for a particular flange.

The charts are categorised as per flange type.

<b>SPO</b>		→	see page 29
<b>ANSI</b>	compact	→	see page 30
	orifice	→	see page 30
	reducing	→	see page 31
<b>DIN</b>	blind	→	see page 32
	threaded	→	see page 32
	weldneck	→	see page 33
	flat	→	see page 33
	lapped	→	see page 33
<b>ASME</b>	series A weld neck	→	see page 34
	series A lapped	→	see page 35
	series A socket welded	→	see page 35
	series B weld neck and blind	→	see page 35
<b>API</b>	6B weld neck	→	see page 36
	6B blind and threaded	→	see page 36
	6BX weld neck	→	see page 36
	6BX blind and test	→	see page 36
<b>BS</b>		→	see page 37



**SPO**

Nominal pipe size	Class															
	150		300		600		900		1500		2500		4500i			
	collet	tool	collet	tool	collet	tool	collet	tool	collet	tool	collet	tool	collet	tool		
1 1/2"													M16 5/8"	SG4TM		
2"													M16 5/8"	SG4TM		
2 1/2"													M20 3/4"	SG4TM		
3"													M16 5/8"	SG4TM		
4"					M16 5/8"	SG4TM	M16 5/8"	SG4TM	M20 3/4"	SG4TM	M24 7/8"	SG6TM	M24 7/8"	SG6TM		
5"					M16 5/8"	SG4TM	M16 5/8"	SG4TM	M24 7/8"	SG6TM	M27 1"	SG6TM	M30 1 1/8"	SG11TM		
6"					M16 5/8"	SG4TM	M16 5/8"	SG4TM	M27 1"	SG6TM	M30 1 1/8"	SG11TM	M33 1 1/4"	SG11TM		
8"			M16 5/8"	SG4TM	M16 5/8"	SG4TM	M20 3/4"	SG4TM	M27 1"	SG6TM	M36 1 3/8"	SG11TM	M39 1 1/2"	SG13TE		
10"			M16 5/8"	SG4TM	M20 3/4"	SG4TM	M24 7/8"	SG6TM	M33 1 1/4"	SG11TM	M39 1 1/2"	SG13TE	M48 1 7/8"	SG15TE		
12"			M16 5/8"	SG4TM	M24 7/8"	SG6TM	M27 1"	SG6TM	M33 1 1/4"	SG11TM	M45 1 3/4"	SG13TE	M48 1 7/8"	SG15TE		
14"			M16 5/8"	SG4TM	M24 7/8"	SG6TM	M27 1"	SG6TM	M36 1 3/8"	SG11TM	M48 1 7/8"	SG15TE	M52 2"	SG15TE		
16"	M16 5/8"	SG4TM	M20 3/4"	SG4TM	M27 1"	SG6TM	M30 1 1/8"	SG11TM	M39 1 1/2"	SG13TE	M60	SG18TE	M60	SG18TE		
18"	M16 5/8"	SG4TM	M20 3/4"	SG4TM	M30 1 1/8"	SG11TM	M33 1 1/4"	SG11TM	M45 1 3/4"	SG13TE	M60	SG18TE	M64 2 1/2"	SG18TE		
20"	M16 5/8"	SG4TM	M24 7/8"	SG6TM	M30 1 1/8"	SG11TM	M36 1 3/8"	SG11TM	M48 1 7/8"	SG15TE	M64 2 1/2"	SG18TE	M84	SG25TE		
22"	M16 5/8"	SG4TM	M24 7/8"	SG6TM	M33 1 1/4"	SG11TM	M39 1 1/2"	SG13TE	M52 2"	SG15TE	M76 3"	SG25TE	M90 3 1/2"	SG25TE		
24"	M20 3/4"	SG4TM	M27 1"	SG6TM	M33 1 1/4"	SG11TM	M42 1 5/8"	SG13TE	M60	SG18TE	M84	SG25TE	M100 4"	SG25TE		
26"	M20 3/4"	SG4TM	M27 1"	SG6TM	M33 1 1/4"	SG11TM	M45 1 3/4"	SG13TE	M60	SG18TE						
28"	M20 3/4"	SG4TM	M27 1"	SG6TM	M36 1 3/8"	SG11TM	M45 1 3/4"	SG13TE	M60	SG18TE						
30"	M20 3/4"	SG4TM	M30 1 1/8"	SG11TM	M36 1 3/8"	SG11TM	M48 1 7/8"	SG15TE	M64 2 1/2"	SG18TE						
32"	M20 3/4"	SG4TM	M30 1 1/8"	SG11TM	M39 1 1/2"	SG13TE	M52 2"	SG15TE	M64 2 1/2"	SG18TE						
34"	M20 3/4"	SG4TM	M33 1 1/4"	SG11TM	M39 1 1/2"	SG13TE	M60	SG18TE	M70 2 3/4"	SG18TE						
36"	M24 7/8"	SG6TM	M33 1 1/4"	SG11TM	M39 1 1/2"	SG13TE	M60	SG18TE	M84	SG25TE						
38"	M24 7/8"	SG6TM	M33 1 1/4"	SG11TM	M39 1 1/2"	SG13TE	M64 2 1/2"	SG18TE	M90 3 1/2"	SG25TE						
40"	M24 7/8"	SG6TM	M33 1 1/4"	SG11TM	M39 1 1/2"	SG13TE	M64 2 1/2"	SG18TE	M84	SG25TE						
42"	M24 7/8"	SG6TM	M36 1 3/8"	SG11TM	M48 1 7/8"	SG15TE	M64 2 1/2"	SG18TE	M95 3 3/4"	SG25TE						
44"	M24 7/8"	SG6TM	M36 1 3/8"	SG11TM	M48 1 7/8"	SG15TE	M64 2 1/2"	SG18TE	M95 3 3/4"	SG25TE						
46"	M24 7/8"	SG6TM	M39 1 1/2"	SG13TE	M48 1 7/8"	SG15TE	M70 2 3/4"	SG18TE	M95 3 3/4"	SG25TE						
48"	M24 7/8"	SG6TM	M39 1 1/2"	SG13TE	M48 1 7/8"	SG15TE	M76 3"	SG25TE	M95 3 3/4"	SG25TE						



## ANSI compact

Nominal pipe size	Class											
	300		600		900		1500		2500			
	collet	tool	collet	tool	collet	tool	collet	tool	collet	tool	collet	tool
1"	no flange		no flange		no flange		no flange		no flange			
1 1/2"												
2"											M16 5/8"	SG4TM
2 1/2"	M16 5/8"	SG4TM	M16 5/8"	SG4TM	M16 5/8"	SG4TM	M16 5/8"	SG4TM	M16 5/8"	SG4TM	M24 7/8"	SG6TM
3"	M16 5/8"	SG4TM	M16 5/8"	SG4TM	M16 5/8"	SG4TM	M16 5/8"	SG4TM	M16 5/8"	SG4TM	M16 5/8"	SG4TM
4"	M20 3/4"	SG4TM	M20 3/4"	SG4TM	M20 3/4"	SG4TM	M20 3/4"	SG4TM	M20 3/4"	SG4TM	M20 3/4"	SG4TM
5"	M20 3/4"	SG4TM	M20 3/4"	SG4TM	M20 3/4"	SG4TM	M20 3/4"	SG4TM	M20 3/4"	SG4TM	M27 1"	SG6TM
6"	M20 3/4"	SG4TM	M20 3/4"	SG4TM	M20 3/4"	SG4TM	M24 7/8"	SG6TM	M30 1 1/8"	SG11TM	M30 1 1/8"	SG11TM
8"	M20 3/4"	SG4TM	M20 3/4"	SG4TM	M20 3/4"	SG4TM	M27 1"	SG6TM	M36 1 3/8"	SG11TM	M45 1 3/4"	SG13TE
10"	M20 3/4"	SG4TM	M20 3/4"	SG4TM	M27 1"	SG6TM	M30 1 1/8"	SG11TM	M45 1 3/4"	SG13TE	M45 1 3/4"	SG13TE
12"	M20 3/4"	SG4TM	M24 7/8"	SG6TM	M30 1 1/8"	SG11TM	M36 1 3/8"	SG11TM	M52 2"	SG15TE	M52 2"	SG15TE
14"	M20 3/4"	SG4TM	M27 1"	SG6TM	M33 1 1/4"	SG11TM	M36 1 3/8"	SG11TM	M45 1 3/4"	SG13TE	M45 1 3/4"	SG13TE
16"	M20 3/4"	SG4TM	M30 1 1/8"	SG11TM	M36 1 3/8"	SG11TM	M42 1 5/8"	SG13TE	M52 2"	SG15TE	M52 2"	SG15TE
18"	M24 7/8"	SG6TM	M33 1 1/4"	SG11TM	M36 1 3/8"	SG11TM	M45 1 3/4"	SG13TE	M56 2 1/4"	SG15TE	M56 2 1/4"	SG15TE
20"	M30 1 1/8"	SG11TM	M36 1 3/8"	SG11TM	M39 1 1/2"	SG13TE	M52 2"	SG15TE	M64 2 1/2"	SG18TE	M64 2 1/2"	SG18TE
24"	M30 1 1/8"	SG11TM	M39 1 1/2"	SG13TE	M45 1 3/4"	SG13TE	M56 2 1/4"	SG15TE	M64 2 1/2"	SG18TE	M64 2 1/2"	SG18TE
30"	M27 1"	SG6TM	M42 1 5/8"	SG13TE	M56 2 1/4"	SG15TE	M70 2 3/4"	SG18TE				
36"	M30 1 1/8"	SG11TM	M45 1 3/4"	SG13TE	M56 2 1/4"	SG15TE	M76 3"	SG25TE				
40"	M30 1 1/8"	SG11TM	M52 2"	SG15TE	M64 2 1/2"	SG18TE	M84	SG25TE				

## ANSI orifice

Nominal pipe size	Class											
	300		400		600		900		1500		2500	
	collet	tool	collet	tool	collet	tool	collet	tool	collet	tool	collet	tool
1"	M16 5/8"	SG4TM	M16 5/8"	SG4TM	M16 5/8"	SG4TM	M24 7/8"	SG6TM	M24 7/8"	SG6TM	M24 7/8"	SG6TM
1 1/2"	M20 3/4"	SG4TM	M20 3/4"	SG4TM	M20 3/4"	SG4TM	M27 1"	SG6TM	M27 1"	SG6TM	M30 1 1/8"	SG11TM
2"	M16 5/8"	SG4TM	M16 5/8"	SG4TM	M16 5/8"	SG4TM	M24 7/8"	SG6TM	M24 7/8"	SG6TM	M27 1"	SG6TM
2 1/2"	M20 3/4"	SG4TM	M20 3/4"	SG4TM	M20 3/4"	SG4TM	M27 1"	SG6TM	M27 1"	SG6TM	M30 1 1/8"	SG11TM
3"	M20 3/4"	SG4TM	M20 3/4"	SG4TM	M20 3/4"	SG4TM	M24 7/8"	SG6TM	M30 1 1/8"	SG11TM	M33 1 1/4"	SG11TM
4"	M20 3/4"	SG4TM	M24 7/8"	SG6TM	M24 7/8"	SG6TM	M30 1 1/8"	SG11TM	M33 1 1/4"	SG11TM	M39 1 1/2"	SG13TE
6"	M20 3/4"	SG4TM	M24 7/8"	SG6TM	M27 1"	SG6TM	M30 1 1/8"	SG11TM	M36 1 3/8"	SG11TM	M52 2"	SG15TE
8"	M24 7/8"	SG6TM	M27 1"	SG6TM	M30 1 1/8"	SG11TM	M36 1 3/8"	SG11TM	M42 1 5/8"	SG13TE	M52 2"	SG15TE
10"	M27 1"	SG6TM	M30 1 1/8"	SG11TM	M33 1 1/4"	SG11TM	M36 1 3/8"	SG11TM	M48 1 7/8"	SG15TE	M64 2 1/2"	SG18TE
12"	M30 1 1/8"	SG11TM	M33 1 1/4"	SG11TM	M33 1 1/4"	SG11TM	M36 1 3/8"	SG11TM	M52 2"	SG15TE	M70 2 3/4"	SG18TE
14"	M30 1 1/8"	SG11TM	M33 1 1/4"	SG11TM	M36 1 3/8"	SG11TM	M39 1 1/2"	SG13TE	M56 2 1/4"	SG15TE		
16"	M33 1 1/4"	SG11TM	M36 1 3/8"	SG11TM	M39 1 1/2"	SG13TE	M42 1 5/8"	SG13TE	M64 2 1/2"	SG18TE	M64 2 1/2"	SG18TE
18"	M33 1 1/4"	SG11TM	M36 1 3/8"	SG11TM	M42 1 5/8"	SG13TE	M48 1 7/8"	SG15TE	M70 2 3/4"	SG18TE		
20"	M33 1 1/4"	SG11TM	M39 1 1/2"	SG13TE	M42 1 5/8"	SG13TE	M52 2"	SG15TE	M76 3"	SG25TE		
24"	M39 1 1/2"	SG13TE	M45 1 3/4"	SG13TE	M48 1 7/8"	SG15TE	M64 2 1/2"	SG18TE	M90 3 1/2"	SG25TE		



## ANSI reducing

Nominal pipe size	Class													
	150		300		400		600		900		1500		2500	
	collet	tool	collet	tool	collet	tool	collet	tool	collet	tool	collet	tool	collet	tool
1/2"									M20 3/4"	SG4TM	M20 3/4"	SG4TM	M20 3/4"	SG4TM
3/4"			M16 5/8"	SG4TM	M16 5/8"	SG4TM	M16 5/8"	SG4TM	M20 3/4"	SG4TM	M20 3/4"	SG4TM	M20 3/4"	SG4TM
1"			M16 5/8"	SG4TM	M16 5/8"	SG4TM	M16 5/8"	SG4TM	M24 7/8"	SG6TM	M24 7/8"	SG6TM	M24 7/8"	SG6TM
1 1/4"			M16 5/8"	SG4TM	M16 5/8"	SG4TM	M16 5/8"	SG4TM	M24 7/8"	SG6TM	M24 7/8"	SG6TM	M27 1"	SG6TM
1 1/2"			M20 3/4"	SG4TM	M20 3/4"	SG4TM	M20 3/4"	SG4TM	M27 1"	SG6TM	M27 1"	SG6TM	M30 1 1/8"	SG11TM
2"	M16 5/8"	SG4TM	M16 5/8"	SG4TM	M16 5/8"	SG4TM	M16 5/8"	SG4TM	M24 7/8"	SG6TM	M24 7/8"	SG6TM	M27 1"	SG6TM
2 1/2"	M16 5/8"	SG4TM	M20 3/4"	SG4TM	M20 3/4"	SG4TM	M20 3/4"	SG4TM	M27 1"	SG6TM	M27 1"	SG6TM	M30 1 1/8"	SG11TM
3"	M16 5/8"	SG4TM	M20 3/4"	SG4TM	M20 3/4"	SG4TM	M20 3/4"	SG4TM	M24 7/8"	SG6TM	M30 1 1/8"	SG11TM	M33 1 1/4"	SG11TM
3 1/2"	M16 5/8"	SG4TM	M20 3/4"	SG4TM	M24 7/8"	SG6TM	M24 7/8"	SG6TM	no flange		no flange		no flange	
4"	M16 5/8"	SG4TM	M20 3/4"	SG4TM	M24 7/8"	SG6TM	M24 7/8"	SG6TM	M30 1 1/8"	SG11TM	M33 1 1/4"	SG11TM	M39 1 1/2"	SG13TE
5"	M20 3/4"	SG4TM	M20 3/4"	SG4TM	M24 7/8"	SG6TM	M27 1"	SG6TM	M33 1 1/4"	SG11TM	M39 1 1/2"	SG13TE	M45 1 3/4"	SG13TE
6"	M20 3/4"	SG4TM	M20 3/4"	SG4TM	M24 7/8"	SG6TM	M27 1"	SG6TM	M30 1 1/8"	SG11TM	M36 1 3/8"	SG11TM	M52 2"	SG15TE
8"	M20 3/4"	SG4TM	M24 7/8"	SG6TM	M27 1"	SG6TM	M30 1 1/8"	SG11TM	M36 1 3/8"	SG11TM	M42 1 5/8"	SG13TE	M52 2"	SG15TE
10"	M24 7/8"	SG6TM	M27 1"	SG6TM	M30 1 1/8"	SG11TM	M33 1 1/4"	SG11TM	M36 1 3/8"	SG11TM	M48 1 7/8"	SG15TE	M64 2 1/2"	SG18TE
12"	M24 7/8"	SG6TM	M30 1 1/8"	SG11TM	M33 1 1/4"	SG11TM	M33 1 1/4"	SG11TM	M36 1 3/8"	SG11TM	M52 2"	SG15TE	M70 2 3/4"	SG18TE
14"	M27 1"	SG6TM	M30 1 1/8"	SG11TM	M33 1 1/4"	SG11TM	M36 1 3/8"	SG11TM	M39 1 1/2"	SG13TE	M56 2 1/4"	SG15TE		
16"	M27 1"	SG6TM	M33 1 1/4"	SG11TM	M36 1 3/8"	SG11TM	M39 1 1/2"	SG13TE	M42 1 5/8"	SG13TE	M64 2 1/2"	SG18TE		
18"	M30 1 1/8"	SG11TM	M33 1 1/4"	SG11TM	M36 1 3/8"	SG11TM	M42 1 5/8"	SG13TE	M48 1 7/8"	SG15TE	M70 2 3/4"	SG18TE		
20"	M30 1 1/8"	SG11TM	M33 1 1/4"	SG11TM	M39 1 1/2"	SG13TE	M42 1 5/8"	SG13TE	M52 2"	SG15TE	M76 3"	SG25TE		
22"	no flange		no flange		no flange		no flange		no flange		no flange			
24"	M33 1 1/4"	SG11TM	M39 1 1/2"	SG13TE	M45 1 3/4"	SG13TE	M48 1 7/8"	SG15TE	M64 2 1/2"	SG18TE	M90 3 1/2"	SG25TE		
26"	M33 1 1/4"	SG11TM	M42 1 5/8"	SG13TE	M42 1 5/8"	SG13TE	M48 1 7/8"	SG15TE	M70 2 3/4"	SG18TE				
28"	M33 1 1/4"	SG11TM	M42 1 5/8"	SG13TE	M42 1 5/8"	SG13TE	M52 2"	SG15TE	M76 3"	SG25TE				
30"	M33 1 1/4"	SG11TM	M45 1 3/4"	SG13TE	M45 1 3/4"	SG13TE	M56 2 1/4"	SG15TE	M76 3"	SG25TE				
32"	M39 1 1/2"	SG13TE	M48 1 7/8"	SG15TE	M48 1 7/8"	SG15TE	M56 2 1/4"	SG15TE	M84	SG25TE				
34"	M39 1 1/2"	SG13TE	M48 1 7/8"	SG15TE	M48 1 7/8"	SG15TE	M56 2 1/4"	SG15TE	M90 3 1/2"	SG25TE				
36"	M39 1 1/2"	SG13TE	M52 2"	SG15TE	M52 2"	SG15TE	M56 2 1/4"	SG15TE	M90 3 1/2"	SG25TE				
38"	M39 1 1/2"	SG13TE	M39 1 1/2"	SG13TE	M39 1 1/2"	SG13TE	M56 2 1/4"	SG15TE	M90 3 1/2"	SG25TE				
40"	M39 1 1/2"	SG13TE	M42 1 5/8"	SG13TE	M42 1 5/8"	SG13TE	M56 2 1/4"	SG15TE	M90 3 1/2"	SG25TE				
42"	M39 1 1/2"	SG13TE	M42 1 5/8"	SG13TE	M42 1 5/8"	SG13TE	M56 2 1/4"	SG15TE	M90 3 1/2"	SG25TE				
44"	M39 1 1/2"	SG13TE	M45 1 3/4"	SG13TE	M45 1 3/4"	SG13TE	M56 2 1/4"	SG15TE	M95 3 3/4"	SG25TE				
46"	M39 1 1/2"	SG13TE	M48 1 7/8"	SG15TE	M48 1 7/8"	SG15TE	M56 2 1/4"	SG15TE	M100 4"	SG25TE				
48"	M39 1 1/2"	SG13TE	M48 1 7/8"	SG15TE	M48 1 7/8"	SG15TE	M70 2 3/4"	SG18TE	M100 4"	SG25TE				



## DIN blind

Nominal pipe size	Class									
	PN16		PN25		PN40		PN64		PN100	
	collet	tool	collet	tool	collet	tool	collet	tool	collet	tool
3/4"									no flange	
1"							M16 5/8"	SG4TM	M16 5/8"	SG4TM
1 1/4"	M16 5/8"	SG4TM	M16 5/8"	SG4TM	M16 5/8"	SG4TM	M20 3/4"	SG4TM	M20 3/4"	SG4TM
1 1/2"	M16 5/8"	SG4TM	M16 5/8"	SG4TM	M16 5/8"	SG4TM	M20 3/4"	SG4TM	M20 3/4"	SG4TM
2"	M16 5/8"	SG4TM	M16 5/8"	SG4TM	M16 5/8"	SG4TM	M20 3/4"	SG4TM	M24 7/8"	SG6TM
2 1/2"	M16 5/8"	SG4TM	M16 5/8"	SG4TM	M16 5/8"	SG4TM	M20 3/4"	SG4TM	M24 7/8"	SG6TM
3"	M16 5/8"	SG4TM	M16 5/8"	SG4TM	M16 5/8"	SG4TM	M20 3/4"	SG4TM	M24 7/8"	SG6TM
4"	M16 5/8"	SG4TM	M20 3/4"	SG4TM	M20 3/4"	SG4TM	M24 7/8"	SG6TM	M27 1"	SG6TM
5"	M16 5/8"	SG4TM	M24 7/8"	SG6TM	M24 7/8"	SG6TM	M27 1"	SG6TM	M30 1 1/8"	SG11TM
6"	M20 3/4"	SG4TM	M24 7/8"	SG6TM	M24 7/8"	SG6TM	M30 1 1/8"	SG11TM	M30 1 1/8"	SG11TM
7"	M20 3/4"	SG4TM	M24 7/8"	SG6TM	M27 1"	SG6TM	M30 1 1/8"	SG11TM	M30 1 1/8"	SG11TM
8"	M20 3/4"	SG4TM	M24 7/8"	SG6TM	M27 1"	SG6TM	M33 1 1/4"	SG11TM	M33 1 1/4"	SG11TM
10"	M24 7/8"	SG6TM	M27 1"	SG6TM	M30 1 1/8"	SG11TM	M33 1 1/4"	SG11TM	M36 1 3/8"	SG11TM
12"	M24 7/8"	SG6TM	M27 1"	SG6TM	M30 1 1/8"	SG11TM	M33 1 1/4"	SG11TM	M39 1 1/2"	SG13TE
14"	M24 7/8"	SG6TM	M30 1 1/8"	SG11TM	M33 1 1/4"	SG11TM	M36 1 3/8"	SG11TM	M45 1 3/4"	SG13TE
16"	M27 1"	SG6TM	M33 1 1/4"	SG11TM	M36 1 3/8"	SG11TM	M39 1 1/2"	SG13TE		
20"	M30 1 1/8"	SG11TM	M33 1 1/4"	SG11TM	M39 1 1/2"	SG13TE				

## DIN threaded

Nominal pipe size	Class									
	PN16		PN25		PN40		PN64		PN100	
	collet	tool	collet	tool	collet	tool	collet	tool	collet	tool
3/4"									M16 5/8"	SG4TM
1"									M16 5/8"	SG4TM
1 1/4"	M16 5/8"	SG4TM	M16 5/8"	SG4TM	M16 5/8"	SG4TM	M16 5/8"	SG4TM	M20 3/4"	SG4TM
1 1/2"	M16 5/8"	SG4TM	M16 5/8"	SG4TM	M16 5/8"	SG4TM	M16 5/8"	SG4TM	M20 3/4"	SG4TM
2"	M16 5/8"	SG4TM	M16 5/8"	SG4TM	M16 5/8"	SG4TM	M20 3/4"	SG4TM	M24 7/8"	SG6TM
2 1/2"	M16 5/8"	SG4TM	M16 5/8"	SG4TM	M16 5/8"	SG4TM	M20 3/4"	SG4TM	M24 7/8"	SG6TM
3"	M16 5/8"	SG4TM	M16 5/8"	SG4TM	M16 5/8"	SG4TM	M20 3/4"	SG4TM	M24 7/8"	SG6TM
4"	M16 5/8"	SG4TM	M20 3/4"	SG4TM	M20 3/4"	SG4TM	M24 7/8"	SG6TM	M27 1"	SG6TM
5"	M16 5/8"	SG4TM	M24 7/8"	SG6TM	M24 7/8"	SG6TM	M24 7/8"	SG6TM	M30 1 1/8"	SG11TM
6"	M16 5/8"	SG4TM	M24 7/8"	SG6TM	M24 7/8"	SG6TM	M30 1 1/8"	SG11TM	M30 1 1/8"	SG11TM





## DIN weldneck

Nominal pipe size	Class											
	PN16		PN25		PN40		PN64		PN100		PN160	
	collet	tool	collet	tool	collet	tool	collet	tool	collet	tool	collet	tool
1"							M16 5/8"	SG4TM	M16 5/8"	SG4TM	M16 5/8"	SG4TM
1 1/4"	M16 5/8"	SG4TM	M16 5/8"	SG4TM	M16 5/8"	SG4TM						
1 1/2"	M16 5/8"	SG4TM	M16 5/8"	SG4TM	M16 5/8"	SG4TM	M20 3/4"	SG4TM	M20 3/4"	SG4TM	M20 3/4"	SG4TM
2"	M16 5/8"	SG4TM	M16 5/8"	SG4TM	M16 5/8"	SG4TM	M20 3/4"	SG4TM	M24 7/8"	SG6TM	M24 7/8"	SG6TM
2 1/2"	M16 5/8"	SG4TM	M16 5/8"	SG4TM	M16 5/8"	SG4TM	M20 3/4"	SG4TM	M24 7/8"	SG6TM	M24 7/8"	SG6TM
3"	M16 5/8"	SG4TM	M16 5/8"	SG4TM	M16 5/8"	SG4TM	M20 3/4"	SG4TM	M24 7/8"	SG6TM	M24 7/8"	SG6TM
4"	M16 5/8"	SG4TM	M16 5/8"	SG4TM	M16 5/8"	SG4TM	M24 7/8"	SG6TM	M27 1"	SG6TM	M27 1"	SG6TM
5"	M16 5/8"	SG4TM	M16 5/8"	SG4TM	M16 5/8"	SG4TM	M27 1"	SG6TM	M30 1 1/8"	SG11TM	M30 1 1/8"	SG11TM
6"	M20 3/4"	SG4TM	M20 3/4"	SG4TM	M20 3/4"	SG4TM	M30 1 1/8"	SG11TM	M30 1 1/8"	SG11TM	M30 1 1/8"	SG11TM
7"	M20 3/4"	SG4TM	M24 7/8"	SG6TM	M20 3/4"	SG4TM	M30 1 1/8"	SG11TM	M30 1 1/8"	SG11TM	M33 1 1/4"	SG11TM
8"	M20 3/4"	SG4TM	M24 7/8"	SG6TM	M20 3/4"	SG4TM	M33 1 1/4"	SG11TM	M33 1 1/4"	SG11TM	M33 1 1/4"	SG11TM
10"	M24 7/8"	SG6TM	M27 1"	SG6TM	M24 7/8"	SG6TM	M33 1 1/4"	SG11TM	M36 1 3/8"	SG11TM	M39 1 1/2"	SG13TE
12"	M24 7/8"	SG6TM	M27 1"	SG6TM	M24 7/8"	SG6TM	M33 1 1/4"	SG11TM	M39 1 1/2"	SG13TE		
14"	M24 7/8"	SG6TM	M30 1 1/8"	SG11TM	M24 7/8"	SG6TM	M36 1 3/8"	SG11TM	M45 1 3/4"	SG13TE		
16"	M27 1"	SG6TM	M33 1 1/4"	SG11TM	M27 1"	SG6TM	M39 1 1/2"	SG13TE				
18"	M27 1"	SG6TM	M33 1 1/4"	SG11TM	M27 1"	SG6TM						
20"	M30 1 1/8"	SG11TM	M33 1 1/4"	SG11TM	M30 1 1/8"	SG11TM						
24"	M33 1 1/4"	SG11TM	M36 1 3/8"	SG11TM								
28"	M33 1 1/4"	SG11TM	M39 1 1/2"	SG13TE								
32"	M36 1 3/8"	SG11TM	M45 1 3/4"	SG13TE								
36"	M36 1 3/8"	SG11TM	M45 1 3/4"	SG13TE								
40"	M39 1 1/2"	SG13TE	M52 2"	SG15TE								
48"	M45 1 3/4"	SG13TE										
56"	M45 1 3/4"	SG13TE										
64"	M52 2"	SG15TE										
72"	M52 2"	SG15TE										
80"	M56 2 1/4"	SG15TE										

## DIN flat

Nominal pipe size	Class			
	PN6		PN10	
	collet	tool	collet	tool
1 1/4"			M16 5/8"	SG4TM
1 1/2"			M16 5/8"	SG4TM
2"			M16 5/8"	SG4TM
2 1/2"			M16 5/8"	SG4TM
3"	M16 5/8"	SG4TM	M16 5/8"	SG4TM
4"	M16 5/8"	SG4TM	M16 5/8"	SG4TM
5"	M16 5/8"	SG4TM	M16 5/8"	SG4TM
6"	M16 5/8"	SG4TM	M20 3/4"	SG4TM
8"	M16 5/8"	SG4TM	M20 3/4"	SG4TM
10"	M16 5/8"	SG4TM	M20 3/4"	SG4TM
12"	M20 3/4"	SG4TM	M20 3/4"	SG4TM
14"	M20 3/4"	SG4TM	M20 3/4"	SG4TM
16"	M20 3/4"	SG4TM	M24 7/8"	SG6TM
18"	M20 3/4"	SG4TM	M24 7/8"	SG6TM
20"	M20 3/4"	SG4TM	M24 7/8"	SG6TM

## DIN lapped

Nominal pipe size	Class			
	PN6		PN10	
	collet	tool	collet	tool
1 1/4"			M16 5/8"	SG4TM
1 1/2"			M16 5/8"	SG4TM
2"			M16 5/8"	SG4TM
2 1/2"			M16 5/8"	SG4TM
3"	M16 5/8"	SG4TM	M16 5/8"	SG4TM
4"	M16 5/8"	SG4TM	M16 5/8"	SG4TM
5"	M16 5/8"	SG4TM	M16 5/8"	SG4TM
6"	M16 5/8"	SG4TM	M20 3/4"	SG4TM
8"	M16 5/8"	SG4TM	M20 3/4"	SG4TM
10"	M16 5/8"	SG4TM	M20 3/4"	SG4TM
12"	M20 3/4"	SG4TM	M20 3/4"	SG4TM
14"	M20 3/4"	SG4TM	M20 3/4"	SG4TM
16"	M20 3/4"	SG4TM	M24 7/8"	SG6TM
18"	M20 3/4"	SG4TM	M24 7/8"	SG6TM
20"	M20 3/4"	SG4TM	M24 7/8"	SG6TM
24"	M24 7/8"	SG6TM	M27 1"	SG6TM
28"	M24 7/8"	SG6TM	M27 1"	SG6TM
32"	M27 1"	SG6TM	M30 1 1/8"	SG11TM
36"	M27 1"	SG6TM		
40"	M27 1"	SG6TM		



## ASME series A weld neck

Nominal pipe size	Class													
	150		300		400		600		900		1500		2500	
	collet	tool	collet	tool	collet	tool	collet	tool	collet	tool	collet	tool	collet	tool
1/2"									M20 3/4"	SG4TM	M20 3/4"	SG4TM	M20 3/4"	SG4TM
3/4"			M16 5/8"	SG4TM	M16 5/8"	SG4TM	M16 5/8"	SG4TM	M20 3/4"	SG4TM	M20 3/4"	SG4TM	M20 3/4"	SG4TM
1"			M16 5/8"	SG4TM	M16 5/8"	SG4TM	M16 5/8"	SG4TM	M24 7/8"	SG6TM	M24 7/8"	SG6TM	M24 7/8"	SG6TM
1 1/4"			M16 5/8"	SG4TM	M16 5/8"	SG4TM	M16 5/8"	SG4TM	M24 7/8"	SG6TM	M24 7/8"	SG6TM	M27 1"	SG6TM
1 1/2"			M20 3/4"	SG4TM	M20 3/4"	SG4TM	M20 3/4"	SG4TM	M27 1"	SG6TM	M27 1"	SG6TM	M30 1 1/8"	SG11TM
2"	M16 5/8"	SG4TM	M16 5/8"	SG4TM	M16 5/8"	SG4TM	M16 5/8"	SG4TM	M24 7/8"	SG6TM	M24 7/8"	SG6TM	M27 1"	SG6TM
2 1/2"	M16 5/8"	SG4TM	M20 3/4"	SG4TM	M20 3/4"	SG4TM	M20 3/4"	SG4TM	M27 1"	SG6TM	M27 1"	SG6TM	M30 1 1/8"	SG11TM
3"	M16 5/8"	SG4TM	M20 3/4"	SG4TM	M20 3/4"	SG4TM	M20 3/4"	SG4TM	M24 7/8"	SG6TM	M30 1 1/8"	SG11TM	M33 1 1/4"	SG11TM
3 1/2"	M16 5/8"	SG4TM	M20 3/4"	SG4TM	M24 7/8"	SG6TM	M24 7/8"	SG6TM						
4"	M16 5/8"	SG4TM	M20 3/4"	SG4TM	M24 7/8"	SG6TM	M24 7/8"	SG6TM	M30 1 1/8"	SG11TM	M33 1 1/4"	SG11TM	M39 1 1/2"	SG13TE
5"	M20 3/4"	SG4TM	M20 3/4"	SG4TM	M24 7/8"	SG6TM	M27 1"	SG6TM	M33 1 1/4"	SG11TM	M39 1 1/2"	SG13TE	M45 1 3/4"	SG13TE
6"	M20 3/4"	SG4TM	M20 3/4"	SG4TM	M24 7/8"	SG6TM	M27 1"	SG6TM	M30 1 1/8"	SG11TM	M36 1 3/8"	SG11TM	M52 2"	SG15TE
8"	M20 3/4"	SG4TM	M24 7/8"	SG6TM	M27 1"	SG6TM	M30 1 1/8"	SG11TM	M36 1 3/8"	SG11TM	M42 1 5/8"	SG13TE	M52 2"	SG15TE
10"	M24 7/8"	SG6TM	M27 1"	SG6TM	M30 1 1/8"	SG11TM	M33 1 1/4"	SG11TM	M36 1 3/8"	SG11TM	M48 1 7/8"	SG15TE	M64 2 1/2"	SG18TE
12"	M24 7/8"	SG6TM	M30 1 1/8"	SG11TM	M33 1 1/4"	SG11TM	M33 1 1/4"	SG11TM	M36 1 3/8"	SG11TM	M52 2"	SG15TE	M70 2 3/4"	SG18TE
14"	M27 1"	SG6TM	M30 1 1/8"	SG11TM	M33 1 1/4"	SG11TM	M36 1 3/8"	SG11TM	M39 1 1/2"	SG13TE	M56 2 1/4"	SG15TE		
16"	M27 1"	SG6TM	M33 1 1/4"	SG11TM	M36 1 3/8"	SG11TM	M39 1 1/2"	SG13TE	M42 1 5/8"	SG13TE	M64 2 1/2"	SG18TE		
18"	M30 1 1/8"	SG11TM	M33 1 1/4"	SG11TM	M36 1 3/8"	SG11TM	M42 1 5/8"	SG13TE	M48 1 7/8"	SG15TE	M70 2 3/4"	SG18TE		
20"	M30 1 1/8"	SG11TM	M33 1 1/4"	SG11TM	M39 1 1/2"	SG13TE	M42 1 5/8"	SG13TE	M52 2"	SG15TE	M76 3"	SG25TE		
22"														
24"	M33 1 1/4"	SG11TM	M39 1 1/2"	SG13TE	M45 1 3/4"	SG13TE	M48 1 7/8"	SG15TE	M64 2 1/2"	SG18TE	M90 3 1/2"	SG25TE		
26"	M33 1 1/4"	SG11TM	M42 1 5/8"	SG13TE	M42 1 5/8"	SG13TE	M48 1 7/8"	SG15TE	M70 2 3/4"	SG18TE				
28"	M33 1 1/4"	SG11TM	M42 1 5/8"	SG13TE	M42 1 5/8"	SG13TE	M52 2"	SG15TE	M76 3"	SG25TE				
30"	M33 1 1/4"	SG11TM	M45 1 3/4"	SG13TE	M45 1 3/4"	SG13TE	M56 2 1/4"	SG15TE	M76 3"	SG25TE				
32"	M39 1 1/2"	SG13TE	M48 1 7/8"	SG15TE	M48 1 7/8"	SG15TE	M56 2 1/4"	SG15TE	M84	SG25TE				
34"	M39 1 1/2"	SG13TE	M48 1 7/8"	SG15TE	M48 1 7/8"	SG15TE	M56 2 1/4"	SG15TE	M90 3 1/2"	SG25TE				
36"	M39 1 1/2"	SG13TE	M52 2"	SG15TE	M52 2"	SG15TE	M56 2 1/4"	SG15TE	M90 3 1/2"	SG25TE				
38"	M39 1 1/2"	SG13TE	M39 1 1/2"	SG13TE	M39 1 1/2"	SG13TE	M56 2 1/4"	SG15TE	M90 3 1/2"	SG25TE				
40"	M39 1 1/2"	SG13TE	M42 1 5/8"	SG13TE	M42 1 5/8"	SG13TE	M56 2 1/4"	SG15TE	M90 3 1/2"	SG25TE				
42"	M39 1 1/2"	SG13TE	M42 1 5/8"	SG13TE	M42 1 5/8"	SG13TE	M56 2 1/4"	SG15TE	M90 3 1/2"	SG25TE				
44"	M39 1 1/2"	SG13TE	M45 1 3/4"	SG13TE	M45 1 3/4"	SG13TE	M56 2 1/4"	SG15TE	M95 3 3/4"	SG25TE				
46"	M39 1 1/2"	SG13TE	M48 1 7/8"	SG15TE	M48 1 7/8"	SG15TE	M56 2 1/4"	SG15TE	M100 4"	SG25TE				
48"	M39 1 1/2"	SG13TE	M48 1 7/8"	SG15TE	M48 1 7/8"	SG15TE	M70 2 3/4"	SG18TE	M100 4"	SG25TE				

## ASME series A lapped

Nominal pipe size	Class													
	150		300		400		600		900		1500		2500	
	collet	tool	collet	tool	collet	tool	collet	tool	collet	tool	collet	tool	collet	tool
1/2"									M20 3/4"	SG4TM	M20 3/4"	SG4TM	M20 3/4"	SG4TM
3/4"			M16 5/8"	SG4TM	M16 5/8"	SG4TM	M16 5/8"	SG4TM	M20 3/4"	SG4TM	M20 3/4"	SG4TM	M20 3/4"	SG4TM
1"			M16 5/8"	SG4TM	M16 5/8"	SG4TM	M16 5/8"	SG4TM	M24 7/8"	SG6TM	M24 7/8"	SG6TM	M24 7/8"	SG6TM
1 1/4"			M16 5/8"	SG4TM	M16 5/8"	SG4TM	M16 5/8"	SG4TM	M24 7/8"	SG6TM	M24 7/8"	SG6TM	M27 1"	SG6TM
1 1/2"			M20 3/4"	SG4TM	M20 3/4"	SG4TM	M20 3/4"	SG4TM	M27 1"	SG6TM	M27 1"	SG6TM	M30 1 1/8"	SG11TM
2"	M16 5/8"	SG4TM	M16 5/8"	SG4TM	M16 5/8"	SG4TM	M16 5/8"	SG4TM	M24 7/8"	SG6TM	M24 7/8"	SG6TM	M27 1"	SG6TM
2 1/2"	M16 5/8"	SG4TM	M20 3/4"	SG4TM	M20 3/4"	SG4TM	M20 3/4"	SG4TM	M27 1"	SG6TM	M27 1"	SG6TM	M30 1 1/8"	SG11TM
3"	M16 5/8"	SG4TM	M20 3/4"	SG4TM	M20 3/4"	SG4TM	M20 3/4"	SG4TM	M24 7/8"	SG6TM	M30 1 1/8"	SG11TM	M33 1 1/4"	SG11TM
3 1/2"	M16 5/8"	SG4TM	M20 3/4"	SG4TM	M24 7/8"	SG6TM	M24 7/8"	SG6TM	no flange	no flange	no flange	no flange	no flange	no flange
4"	M16 5/8"	SG4TM	M20 3/4"	SG4TM	M24 7/8"	SG6TM	M24 7/8"	SG6TM	M30 1 1/8"	SG11TM	M33 1 1/4"	SG11TM	M39 1 1/2"	SG13TE
5"	M20 3/4"	SG4TM	M20 3/4"	SG4TM	M24 7/8"	SG6TM	M27 1"	SG6TM	M33 1 1/4"	SG11TM	M39 1 1/2"	SG13TE	M45 1 3/4"	SG13TE
6"	M20 3/4"	SG4TM	M20 3/4"	SG4TM	M24 7/8"	SG6TM	M27 1"	SG6TM	M30 1 1/8"	SG11TM	M36 1 3/8"	SG11TM	M52 2"	SG15TE
8"	M20 3/4"	SG4TM	M24 7/8"	SG6TM	M27 1"	SG6TM	M30 1 1/8"	SG11TM	M36 1 3/8"	SG11TM	M42 1 5/8"	SG13TE	M52 2"	SG15TE
10"	M24 7/8"	SG6TM	M27 1"	SG6TM	M30 1 1/8"	SG11TM	M33 1 1/4"	SG11TM	M36 1 3/8"	SG11TM	M48 1 7/8"	SG15TE	M64 2 1/2"	SG18TE
12"	M24 7/8"	SG6TM	M30 1 1/8"	SG11TM	M33 1 1/4"	SG11TM	M33 1 1/4"	SG11TM	M36 1 3/8"	SG11TM	M52 2"	SG15TE	M70 2 3/4"	SG18TE

## ASME series A socket welded

Nominal pipe size	Class							
	150		300		600		1500	
	collet	tool	collet	tool	collet	tool	collet	tool
1/2"							M20 3/4"	SG4TM
3/4"			M16 5/8"	SG4TM	M16 5/8"	SG4TM	M20 3/4"	SG4TM
1"			M16 5/8"	SG4TM	M16 5/8"	SG4TM	M24 7/8"	SG6TM
1 1/4"			M16 5/8"	SG4TM	M16 5/8"	SG4TM	M24 7/8"	SG6TM
1 1/2"			M20 3/4"	SG4TM	M20 3/4"	SG4TM	M27 1"	SG6TM
2"	M16 5/8"	SG4TM	M16 5/8"	SG4TM	M16 5/8"	SG4TM	M24 7/8"	SG6TM
2 1/2"	M16 5/8"	SG4TM	M20 3/4"	SG4TM	M20 3/4"	SG4TM	M27 1"	SG6TM
3"	M16 5/8"	SG4TM	M20 3/4"	SG4TM	M20 3/4"	SG4TM		

## ASME series B weld neck and blind

Nominal pipe size	Class									
	150		300		400		600		900	
	collet	tool	collet	tool	collet	tool	collet	tool	collet	tool
26"	M20 3/4"	SG4TM	M33 1 1/4"	SG11TM	M36 1 3/8"	SG11TM	M42 1 5/8"	SG13TE	M64 2 1/2"	SG18TE
28"	M20 3/4"	SG4TM	M33 1 1/4"	SG11TM	M39 1 1/2"	SG13TE	M45 1 3/4"	SG13TE	M70 2 3/4"	SG18TE
30"	M20 3/4"	SG4TM	M36 1 3/8"	SG11TM	M39 1 1/2"	SG13TE	M48 1 7/8"	SG15TE	M76 3"	SG25TE
32"	M20 3/4"	SG4TM	M39 1 1/2"	SG13TE	M42 1 5/8"	SG13TE	M52 2"	SG15TE	M76 3"	SG25TE
34"	M24 7/8"	SG6TM	M39 1 1/2"	SG13TE	M42 1 5/8"	SG13TE	M56 2 1/4"	SG15TE	M80 3 1/4"	SG25TE
36"	M24 7/8"	SG6TM	M42 1 5/8"	SG13TE	M45 1 3/4"	SG13TE	M56 2 1/4"	SG15TE	M76 3"	SG25TE
42"	M27 1"	SG6TM	M45 1 3/4"	SG13TE						
48"	M30 1 1/8"	SG11TM	M48 1 7/8"	SG15TE						
54"	M30 1 1/8"	SG11TM	M48 1 7/8"	SG15TE						
60"	M33 1 1/4"	SG11TM	M56 2 1/4"	SG15TE						

## API 6B weld neck

Nominal pipe size	Class					
	138 bar (2000 psi)		207 bar (3000 psi)		345 bar (5000 psi)	
	collet	tool	collet	tool	collet	tool
2 1/16"	M16 5/8"	SG4TM	M24 7/8"	SG6TM	M24 7/8"	SG6TM
2 9/16"	M20 3/4"	SG4TM	M27 1"	SG6TM	M27 1"	SG6TM
3 1/8"	M20 3/4"	SG4TM	M24 7/8"	SG6TM	M30 1 1/8"	SG11TM
4 1/16"	M24 7/8"	SG6TM	M30 1 1/8"	SG11TM	M33 1 1/4"	SG11TM
5 1/8"	M27 1"	SG6TM	M33 1 1/4"	SG11TM	M39 1 1/2"	SG13TE
7 1/16"	M27 1"	SG6TM	M30 1 1/8"	SG11TM	M36 1 3/8"	SG11TM
9"	M30 1 1/8"	SG11TM	M36 1 3/8"	SG11TM	M42 1 5/8"	SG13TE
11"	M33 1 1/4"	SG11TM	M36 1 3/8"	SG11TM	M48 1 7/8"	SG15TE

## API 6B blind and threaded

Nominal pipe size	Class					
	138 bar (2000 psi)		207 bar (3000 psi)		345 bar (5000 psi)	
	collet	tool	collet	tool	collet	tool
2 1/16"	M16 5/8"	SG4TM	M24 7/8"	SG6TM	M24 7/8"	SG6TM
2 9/16"	M20 3/4"	SG4TM	M27 1"	SG6TM	M27 1"	SG6TM
3 1/8"	M20 3/4"	SG4TM	M24 7/8"	SG6TM	M30 1 1/8"	SG11TM
4 1/16"	M24 7/8"	SG6TM	M30 1 1/8"	SG11TM	M33 1 1/4"	SG11TM
5 1/8"	M27 1"	SG6TM	M33 1 1/4"	SG11TM	M39 1 1/2"	SG13TE
7 1/16"	M27 1"	SG6TM	M30 1 1/8"	SG11TM	M36 1 3/8"	SG11TM
9"	M30 1 1/8"	SG11TM	M36 1 3/8"	SG11TM	M42 1 5/8"	SG13TE
11"	M33 1 1/4"	SG11TM	M36 1 3/8"	SG11TM	M48 1 7/8"	SG15TE
13 5/8"	M33 1 1/4"	SG11TM	M36 1 3/8"	SG11TM		
16 3/4"	M39 1 1/2"	SG13TE	M42 1 5/8"	SG13TE		
21 1/4"	M42 1 5/8"	SG13TE	M52 2"	SG15TE		

## API 6BX weld neck

Nominal pipe size	Class					
	690 bar (10000 psi)		1035 bar (15000 psi)		1380 bar (20000 psi)	
	collet	tool	collet	tool	collet	tool
1 13/16"	M20 3/4"	SG4TM	M24 7/8"	SG6TM	M27 1"	SG6TM
2 1/16"	M20 3/4"	SG4TM	M24 7/8"	SG6TM	M30 1 1/8"	SG11TM
2 9/16"	M24 7/8"	SG6TM	M27 1"	SG6TM	M33 1 1/4"	SG11TM
3 1/16"	M27 1"	SG6TM	M30 1 1/8"	SG11TM	M36 1 3/8"	SG11TM
4 1/16"	M30 1 1/8"	SG11TM	M36 1 3/8"	SG11TM	M45 1 3/4"	SG13TE
5 1/8"	M30 1 1/8"	SG11TM				
7 1/16"	M39 1 1/2"	SG13TE	M39 1 1/2"	SG13TE	M52 2"	SG15TE
9"	M39 1 1/2"	SG13TE				
11"	M45 1 3/4"	SG13TE				
13 5/8"	M48 1 7/8"	SG15TE				
16 3/4"	M48 1 7/8"	SG15TE				

## API 6BX blind and test

Nominal pipe size	Class					
	690 bar (10000 psi)		1035 bar (15000 psi)		1380 bar (20000 psi)	
	collet	tool	collet	tool	collet	tool
1 13/16"	M20 3/4"	SG4TM	M24 7/8"	SG6TM	M27 1"	SG6TM
2 1/16"	M20 3/4"	SG4TM	M24 7/8"	SG6TM	M30 1 1/8"	SG11TM
2 9/16"	M24 7/8"	SG6TM	M27 1"	SG6TM	M33 1 1/4"	SG11TM
3 1/16"	M27 1"	SG6TM	M33 1 1/4"	SG11TM	M36 1 3/8"	SG11TM
4 1/16"	M30 1 1/8"	SG11TM	M42 1 5/8"	SG13TE	M45 1 3/4"	SG13TE

