



FLANGE TOOL INNOVATION



Equalizer International is an award-winning, world-leading designer and supplier of innovative flange maintenance tools for the oil and gas, petrochemical, nuclear, water, mining and renewable energy sectors.

Established in Scotland in 1994, we have designed and developed more than 20 tools across a product range which includes flange aligning, spreading and pulling tools together with a series of hand pumps and lifting tools and our latest innovation, the Equalizer NS Nutsplitter range.

Innovation remains at the very heart of our company and we have more than 60 active patents, trade-marks and design registrations in our expanding global intellectual portfolio. Our tools are sold in 50 countries and are used around the world to resolve hundreds of technically-challenging flange joint applications while delivering significant safety, time and cost savings benefits. In addition to our standard products, our designers and engineers also work closely with customers on an individual basis to develop customised solutions to particular problems.

A truly-customer focussed organisation, many of the new tools we develop result from direct conversations with you, the customer. We understand the operational challenges you face and we respond by pushing out the boundaries of design and development to provide straightforward, highly efficient solutions.

As our product range continues to grow our tools will always be built on the combined experience, creativity and innovation that have helped shape the Equalizer brand – **FLANGE TOOL INNOVATION.**

CONTENTS

1. FLANGE SPREADING SOLUTIONS	3
SWi RANGE	4
SWi12/14TM	5
SWi20/25TE	6
SWi20/25TI	7
SG RANGE	8
SG4TM	9
SG6TM	9
SG11TM	9
SG13TE	10
SG15TE	10
SG18TE	11
SG25TE	11
VC RANGE	12
VC10/13TE	14
VC10/15TE	15
VC10/18TE	15
VC10/25TE	15
ADDITIONAL SPREADING TOOLS	16
SW15TE	16
SW14.5TI	17
SW9TM	17
MG7TM	17
2. FLANGE ALIGNMENT SOLUTIONS	18
FA1TM	20
FA4TM	21
FA9TE	22
TFA15TI	23
3. NUT SPLITTING SOLUTIONS	24
NS12TE / NS12TI	26
NS15TE / NS15TI	27
NS20TE / NS20TI	27
NS36TE	27
4. FLANGE PULLING SOLUTIONS	28
FC10TE	29
5. PRECISION LIFTING SOLUTIONS	30
VLW18TE	30
VLW18TI	30
6. HYDRAULIC HAND-PUMPS	31
HP350/550/1000S	31
HP350/550/1000D	31
HP350/550/1000SD	31
7. PRODUCT TRAINING	32
8. ONLINE SUPPORT	34
9. GLOBAL DISTRIBUTION	35

1. FLANGE SPREADING SOLUTIONS

The Equalizer™ range of patented flange spreading tools has been developed to aid and simplify the maintenance of flange joints. No longer will those tasked with separating flanges have to rely on using ropes and pulleys, podgers, tirsors, come-alongs or hammers – there is a safe, quick and effective alternative, the Equalizer™ range of spreaders. These spreaders use mechanical and hydraulic principles for separating flanges and can spread small, medium or large flange joints. Tool selection is made on the basis of the access gap between the flange faces:

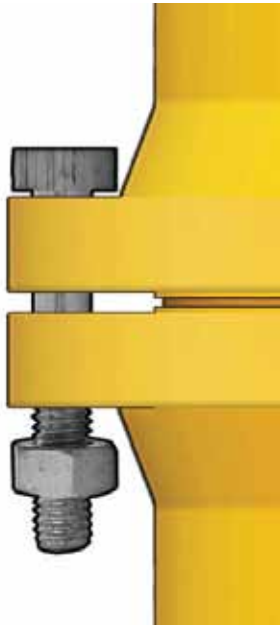

MG Tool:

The safest tool for small diameter, low pressure flanges with an access gap of at least 2.0mm.



SWi Range:

The world's safest and most powerful flange spreading wedge for use on small, medium or large flange joints with an access gap of at least 6.0mm.

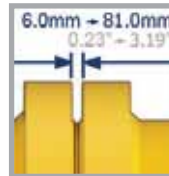

SW Range:

A general purpose spreading wedge for use on small, medium or large flange joints with an access gap of at least 6.0mm.



SG Range:

A globally unique spreader for use on flange joints with no access gap, or where there is a spacer, wafer or butterfly valve positioned between the flanges.

SWi RANGE

INNOVATIVE FLANGE SPREADING WEDGES

The SWi range has set the new standard for spreading flange joints powerfully, efficiently, effectively and safely. The tools offer the following features and benefits:

Wider spreading - using the supplied Stepped Block accessories means the SWi range offers up to 30% more flange spreading distance than a traditional SW tool.

Unrivalled power - the tools now offer up to 25T of spreading force, which provides additional confidence when spreading.

Narrower jaws - the SWi tools are 8% narrower than the traditional SW range to help them fit more easily between flange bolts.

Safer working – the 360-degree swivel lanyard on all SWi tools enables users to attach the spreader to some adjacent pipework, mitigating potential dropped object injury.

Fully rotational handle – the handle swivels 360-degrees around the wedge

head, so that the SWi tools can be used comfortably in all orientations.

Lighter tools – the SWi tools are on average lighter than the traditional SW spreaders and are therefore easier to carry on-site and to use.

Better handle grips – the SWi comes with a reinforced composite handle making it easier to grip, hold and use.

Safety blocks - designed to suit the step sizes of the SWi tools, the supplied safety blocks accommodate the wider spread offered when the stepped blocks are fitted.

Easier maintenance – end-users will appreciate the ease with which the tools can be maintained. The supplied hex-key and a two step-process is all that's required to disassemble and reassemble the tools.

No pinch points – the SWi range of tools has been engineered to overcome finger pinch-points.



SWi12/14™

INNOVATIVE MECHANICAL FLANGE SPREADING WEDGE

This innovative spreading wedge is applicable for use on small to medium sized flanges and is mechanically operated using the supplied torque-wrench.



TOOL CAPABILITIES

SPREADING FORCE

with 175N.m (130ft.lb) torque applied:

- 120kN (12T) 1st step
- 140kN (14T) 4th step

SPREADING DISTANCE

- 6.0mm – 40.0mm (0.24" - 1.6") using only 1st step
- 6.0mm – 87.5mm (0.24" - 3.4") using 4 steps (without stepped blocks)
- 48.5mm – 103.5mm (1.9" - 4.1") using 2 steps (with stepped blocks)

TOOL WEIGHT

- 6.2kg (13.7lb)



STANDARD KIT



SWi20/25TE

INNOVATIVE EXTERNAL HYDRAULIC FLANGE SPREADING WEDGE

This innovative spreading wedge is applicable for use on medium to large sized flanges and is actuated by an external hydraulic hand-pump.



TOOL CAPABILITIES

SPREADING FORCE

with 700bar (10,000psi) hydraulic pressure applied:

- 200kN (20T) 1st step
- 240kN (24T) 4th step

SPREADING DISTANCE

- 6.0mm – 40.0mm (0.24" - 1.6")
using only 1st step
- 6.0mm – 87.5mm (0.24" - 3.4")
using 4 steps (without stepped blocks)
- 48.5mm – 103.5mm (1.9" - 4.1")
using 2 steps (with stepped blocks)

TOOL WEIGHT: 6.4kg (14.10lb)

Available in three kit formats:



MINI KIT
(SWi2025TEMIN)

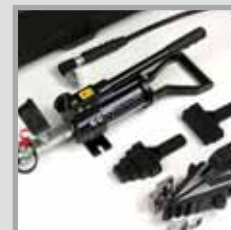

STANDARD KIT
(SWi2025TESTDSPB)



MAXI KIT
(SWi2025TEMAXSPB)



SWi20/25TI

INNOVATIVE INTEGRAL HYDRAULIC FLANGE SPREADING WEDGE

This self-contained, compact and portable innovative spreading wedge is applicable for use on medium to large sized flanges and is actuated by an integral hydraulic hand-pump, so no hoses or external pumps are required.



TOOL CAPABILITIES

SPREADING FORCE

with 700bar (10,000psi) hydraulic pressure applied:

- 200kN (20T) 1st step
- 240kN (24T) 4th step

SPREADING DISTANCE

- 6.0mm – 40.0mm (0.24" - 1.6") using only 1st step
- 6.0mm – 87.5mm (0.24" - 3.4") using 4 steps (without stepped blocks)
- 48.5mm – 103.5mm (1.9" - 4.1") using 2 steps (with stepped blocks)

TOOL WEIGHT

- 8.5kg (18.8lb)



STANDARD KIT



SG RANGE

SECURE-GRIP FLANGE SPREADING TOOLS

Equalizer's globally unique Secure-Grip tools spread via the flange bolt holes and offer, arguably the world's safest flange spreading tools.

These tools use our patented expanding collet technology for application on flanges with a zero gap or where spacers, spectacles or butterfly valves reside between the flange joints.

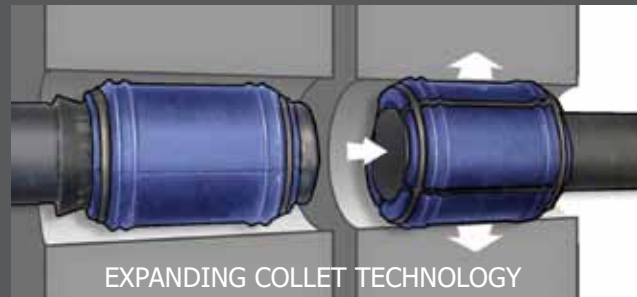

SHORT COLLET HOLDER KITS

TOOL	Configuration	C ₁ (Closed)	C ₂ (Open)
SG4TM	standard tool (i)	0mm (0")	75mm (2.95")
	single SCH kit (ii)	42mm (1.65")	117mm (4.61")
	double SCH kit (iii)	84mm (3.31")	159mm (6.26")
SG6TM	standard tool (i)	0mm (0")	80mm (3.15")
	single SCH kit (ii)	60mm (1.42")	140mm (4.57")
	double SCH kit (iii)	120mm (4.72")	200mm (7.87")
SG11TM	standard tool (i)	0 mm (0")	90mm (3.50")
	single SCH kit (ii)	13mm (0.51")	103mm (4.06")
	double SCH kit (iii)	26mm (1.02")	116mm (4.57")

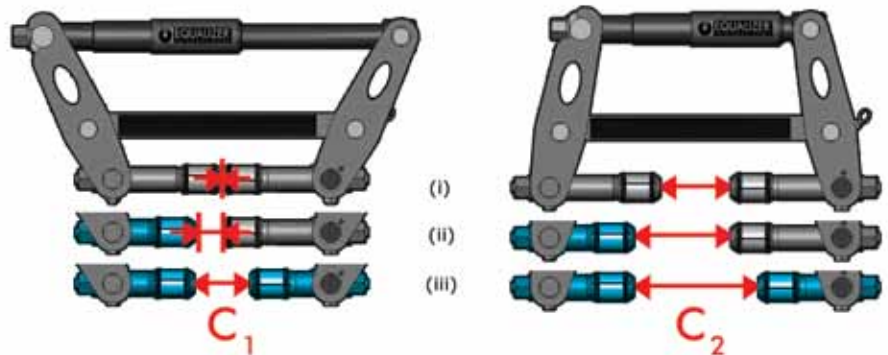

A Short Collet Holder Kit is available for each mechanical Secure-Grip tool. The kit fits on in place of the standard Collet Holder, and uses the standard Collets.



SG4TM SG6TM SG11TM



SECURE-GRIP MECHANICAL FLANGE SPREADERS

The smaller lightweight mechanical SG tools are applicable for small to medium sized flanges, are actuated by the supplied torque wrench, and are suitable for bolt holes from 17.5mm (0.69") to 39.0mm (1.54"). Different collets are used to match the tool to the respective bolt hole diameter.



TOOL CAPABILITIES

- **SG4TM:**
spreading force of 37kN (3.7T);
spreading distance of 75.0mm (2.95")
tool weight: 4.5kg (10.0lb)
- **SG6TM:**
spreading force of 60kN (6T);
spreading distance of 80.0mm (3.15")
tool weight: 7.5kg (16.5lb)
- **SG11TM:**
spreading force of 110kN (11T);
spreading distance of 90.0mm (3.55")
tool weight: 10.5kg (23.2lb)



SG4TM KIT

Includes Collets:
M16 (5/8")
M20 (3/4")

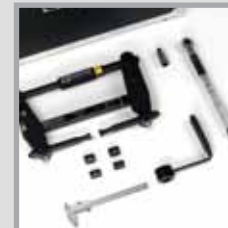

SG6TM KIT

Includes Collets:
M24 (7/8")
M27 (1")



SG11TM KIT

Includes Collets:
M30 (1-1/8")
M33 (1-1/4")
M36 (1-3/8")



SG13TE SG15TE



SECURE-GRIP HYDRAULIC FLANGE SPREADERS

The hydraulic SG tools are applicable for medium to large sized flanges, are actuated by an external hand-pump and are suitable for bolt holes from 38.0mm (1.49") to 62.0mm (2.44"). Different collets are used to match the tool to the respective bolt hole diameter.



TOOL CAPABILITIES

- SG13TE:
spreading force of 130kN (13T);
spreading distance of 115.0mm
(4.53")
tool weight: 21.5kg (47.4lb)
- SG15TE:
spreading force of 150kN (15T);
spreading distance of 100.0mm
(3.94")
tool weight: 26.0kg (57.3lb)



SG13TE KIT

Includes Collets:
M39 (1-1/2")
M42 (1-5/8")
M45 (1-3/4")



SG15TE KIT

Includes Collets:
M48 (1-7/8")
M52 (2")
M56 (2-1/4")



SG18TE SG25TE



SECURE-GRIP IN-LINE HYDRAULIC FLANGE SPREADERS

The large in-line hydraulic SG tools are applicable for larger sized flanges. These are actuated by an external hand-pump and are suitable for bolt holes from 59.5mm (2.34") to 108.0mm (4.25"). Different collets are used to match the tool to the respective bolt hole diameter.



TOOL CAPABILITIES

- SG18TE:
spreading force of 180kN (18T);
spreading distance of 100.0mm (3.94")
tool weight: 14.0kg (30.9lb)
- SG25TE:
spreading force of 250kN (25T);
spreading distance of 120.0mm (4.72")
tool weight: 24.0kg (52.9lb)



SG18TE KIT

Includes Collets:
M60
M64 (2-1/2")
M70 (2-3/4")



SG25TE KIT
(collets supplied separately)

Collets :
M76 (3") M90 (3-1/2")
M80 (3-1/4") M95 (3-3/4")
M84 M100 (4")

VC RANGE

SECURE-GRIP VALVE-CHANGE-OUT FLANGE SPREADING TOOLS

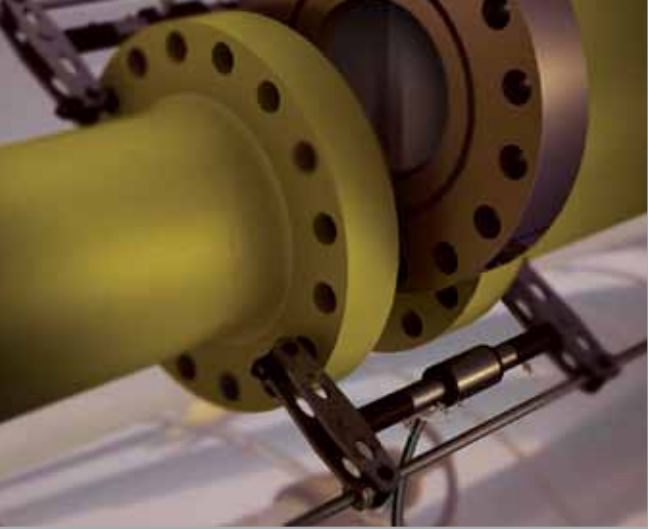

The Equalizer™ VC Range of Valve Change-Out tools has been developed to assist in the removal of wafer/butterfly valves, spades/spacers or gaskets from large flange joints. The span of the tool is longer than a standard Secure-Grip Flange Spreader and is adjustable to enable the tool to operate in a range of situations.

IDEAL FOR:

Large flange joints

Flange joints with spacers, blinds, or valves present

Spreading force up to 10T per tool





NEW
PRODUCT

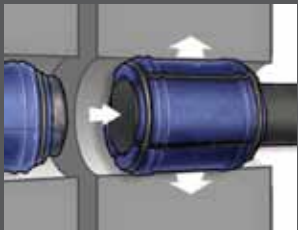

UNIQUE EXPANDING COLLET TECHNOLOGY

little or no access gap required
secure bolt-hole locking mechanism

unique technology makes the Secure-Grip arguably the safest flange spreader available in the world today

time-saving, simple operation

measurable, controlled spreading force

INFINITELY RECONFIGURABLE

By utilising the supplied extensions and adjusting the length of the tension rod, the tools can be reconfigured to suit a huge range of flange joint thicknesses, from 0 to 550mm.

Additional kits are available to further extend the range of application.

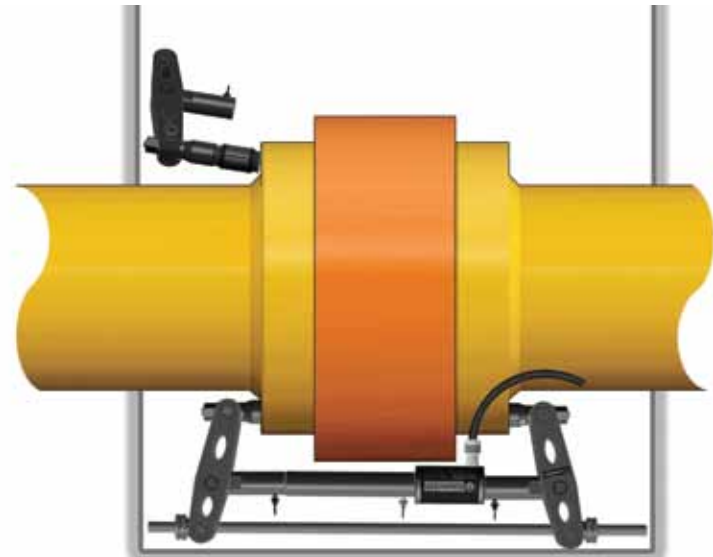



VC10/13TE

SECURE-GRIP VALVE CHANGE-OUT TOOL

The VC Range consists of several tool variations, each with its own set of collets designed to suit a range of bolt-hole sizes. The unique patented expanding collet technology is shared with the Secure-Grip range.

Contact us if you have an application that is beyond the capability of our standard tools, various kits that extend the range are available.

For larger flange joints (or those with a spacer or valve between the flanges) with bolt hole diameter between 38.0mm and 49.0mm (1.50" to 1.93")

Minimum bolt-hole diameter (mm)	Maximum bolt-hole diameter (mm)	COLLET	TOOL
38 (1.50")	42 (1.65")	M39	VC10/13TE
41 (1.61")	45 (1.77")	M42	
44 (1.73")	49 (1.93")	M45	
47.5 (1.87")	52 (2.05")	M48	VC10/15TE
50.5 (1.99")	56 (2.20")	M52	
55.5 (2.19")	62 (2.44")	M56	
59.5 (2.34")	63 (2.48")	M60	VC10/18TE
63 (2.48")	69 (2.72")	M64	
69 (2.72")	75 (2.95")	M70	
75 (2.95")	81 (3.19")	M76	VC10/25TE
79 (3.11")	86 (3.39")	M80	
83 (3.27")	88 (3.46")	M84	
88 (3.46")	94 (3.70")	M90	
94 (3.70")	101 (3.98")	M95	
99 (3.90")	107 (4.21")	M100	

SPREADING FORCE

with 700bar (10,000psi) hydraulic pressure applied:

- 100kN (10.0T)

SPREADING DISTANCE

- 151mm (5.9")

VC10/15TE

SECURE-GRIP VALVE
CHANGE-OUT TOOL

For larger flange joints (or those with a spacer or valve between the flanges) with bolt hole diameter between 47.0mm and 62.0mm (1.85" to 2.44")

VC10/18TE

SECURE-GRIP VALVE
CHANGE-OUT TOOL

For larger flange joints (or those with a spacer or valve between the flanges) with bolt hole diameter between 59.0mm and 75.0mm (2.32" to 2.95")

VC10/25TE

SECURE-GRIP VALVE
CHANGE-OUT TOOL

For larger flange joints (or those with a spacer or valve between the flanges) with bolt hole diameter between 75.0mm and 107.0mm (2.95" to 4.21")



NEW
PRODUCT

TYPICAL VC STANDARD KIT



TYPICAL VC MAXI KIT





ADDITIONAL SPREADING TOOLS

COMPLETING THE
SPREADER RANGE



SW15TE

HYDRAULIC FLANGE
SPREADING WEDGE

This general purpose spreading wedge is actuated by an external hydraulic hand-pump.

TOOL CAPABILITIES

SPREADING FORCE

with 700bar (10,000psi) hydraulic pressure applied:

- 155kN (15.5T)

SPREADING DISTANCE

- 6.0mm – 31.0mm (0.24" - 1.22")
using only 1st step
- 6.0mm – 62.0mm (0.24" - 2.44")
using 4 steps
(without stepped blocks)
- 31.0mm – 81.0mm (1.22" - 3.19")
using optional stepped blocks kit

TOOL WEIGHT: 7.0kg (15.4lb)



SW14.5TI

INTEGRAL HYDRAULIC FLANGE SPREADING WEDGE

This general purpose self-contained spreading wedge is actuated by an integral hydraulic hand-pump, so no hoses or external pumps are required.



SW9TM

MECHANICAL FLANGE SPREADING WEDGE

This general purpose, entry level spreading wedge is mechanically operated using the supplied torque-wrench.



MG7TM

MINI-GAP FLANGE SPREADER WEDGE

For use on smaller, lower pressure flange joints, this portable and flexible tool can be assembled in two alternative configurations to suit a range of flanges.

TOOL CAPABILITIES

SPREADING FORCE

with 700bar (10,000psi) hydraulic pressure applied:

- 145kN (14.5T)

SPREADING DISTANCE

- 6.0mm – 31.0mm (0.24" - 1.22") using only 1st step
- 6.0mm – 62.0mm (0.24" - 2.44") using 4 steps (without stepped blocks)
- 31.0mm – 81.0mm (1.22" - 3.19") using optional stepped blocks kit

TOOL WEIGHT: 9.0kg (19.8lb)

TOOL CAPABILITIES

SPREADING FORCE

with 203N.m (150ft.lb) torque applied:

- 90kN (9T)

SPREADING DISTANCE

- 6.0mm – 31.0mm (0.24" - 1.22") using only 1st step
- 6.0mm – 62.0mm (0.24" - 2.44") using 4 steps (without stepped blocks)
- 31.0mm – 81.0mm (1.22" - 3.19") using optional stepped blocks kit

TOOL WEIGHT: 5.5kg (12.13lb)

TOOL CAPABILITIES

SPREADING FORCE

single tool:

- 68kN (6.8T)

used in pairs (as recommended):

- 136kN (13.6T)

SPREADING DISTANCE

- 2.0mm - 27.0mm (0.08" - 1.06")

TOOL WEIGHT: 5.0kg (11.0lb)



Alignment of flanges is an essential part of ensuring a leak-free bolted flange joint.

There are many causes of misalignment; over-hanging weight, pipe support positioning and fabrication tolerances for example. Traditionally these have been rectified by the use of chain blocks, pulleys, come-alongs and other rigging equipment.

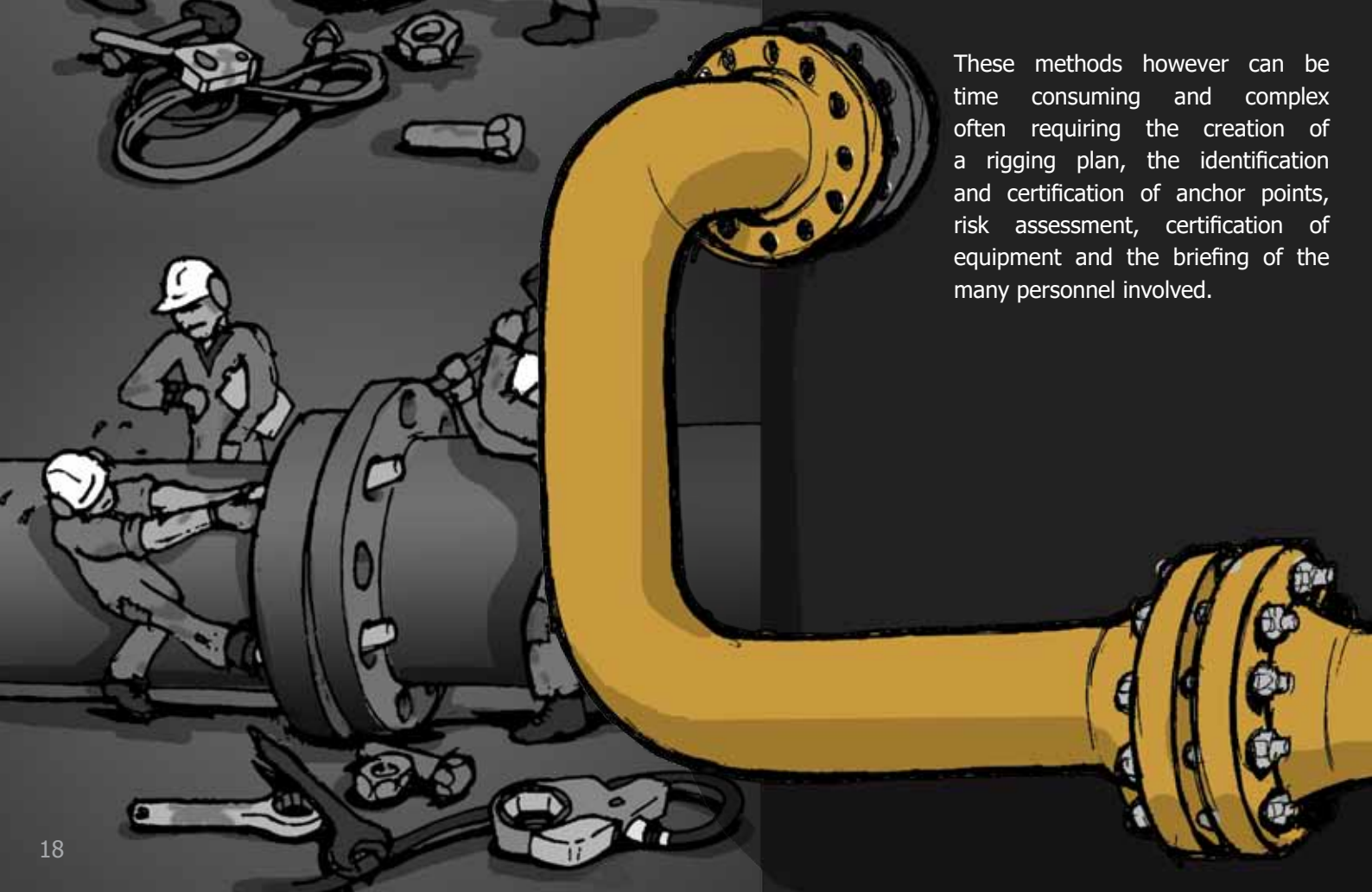

These methods however can be time consuming and complex often requiring the creation of a rigging plan, the identification and certification of anchor points, risk assessment, certification of equipment and the briefing of the many personnel involved.

2. FLANGE ALIGNMENT SOLUTIONS

The Equalizer™ patented range of alignment tools addresses the rotational or lateral misalignment that can occur within flange joints. Compared with traditional, manual approaches, the Equalizer™ tools offer a much safer, quicker and effective means of realigning flanges.



APPLICATIONS

Our Flange Alignment tools can be used to resolve lateral or rotational misalignment during:

- commissioning
- construction
- routine maintenance
- shut-downs or outages
- testing
- valve change-outs

SPECIAL FEATURES

- operate on most pipe configurations
- use on horizontal or vertical flanges including ANSI/ASME, API, BS, DIN and SPO

- suitable for offshore and onshore applications

OPERATING BENEFITS

Using our Flange Alignment tools:

- saves time
- saves cost
- optimises staffing
- promotes work continuity
- encourages safer working practice
- enables efficient operation
- lightweight and portable - ideal for remote locations or confined environments
- dispenses with need for cranes, tirsors and hooks



FA1™

MECHANICAL FLANGE ALIGNMENT TOOL

This portable, robust lightweight tool is a simple solution for small low-pressure flange misalignment requirements. It is hand-actuated using the crank handle.



TOOL CAPABILITIES

ALIGNING FORCE

- 10kN (1T)

APPLICATION RANGE

- Minimum Bolt Hole Diameter: 16.0mm (0.63")
- Maximum Aligning Distance: 26.0mm (1.02")

TOOL WEIGHT

- 1.6kg (3.5lb)



STANDARD KIT

FA4™

MECHANICAL LINEAR AND ROTATIONAL FLANGE ALIGNMENT TOOL

This mid-range mechanical tool is for use on medium diameter, medium pressure flanges, and can address both rotational and radial misalignment. It is actuated by the supplied torque-wrench.



TOOL CAPABILITIES

ALIGNING FORCE

with 68N.m (50ft.lb) of torque applied:

- 40kN (4T)

APPLICATION RANGE

- Minimum Bolt Hole Diameter: 25.0mm (1.00")
- Maximum Wing Reach: 158.0mm (6.22")

TOOL WEIGHT

- 8.6kg (19.0lb)



STANDARD KIT



FA9TE

HYDRAULIC LINEAR AND ROTATIONAL FLANGE ALIGNMENT TOOL

This hydraulic tool is for use on larger diameter, higher pressure flanges, and can address both rotational and radial misalignment. It is actuated by an external hydraulic pump.



TOOL CAPABILITIES

ALIGNING FORCE

with 700bar (10,000psi) hydraulic pressure applied:

- 90kN (9T)

APPLICATION RANGE

- Minimum Bolt Hole Diameter: 35.5mm (1.40")
- Maximum Wing Reach: 240.0mm (9.45")

TOOL WEIGHT

- 14.5kg (32.0lb)



STANDARD KIT



TFA15TI

WIND TURBINE TOWER HYDRAULIC FLANGE ALIGNMENT TOOL

The Equalizer™ TFA15TI hydraulic flange alignment tool has been developed to aid the alignment of large flanges on the inside of wind turbine towers. This tool assists with the installation of wind turbine tower sections making it simpler, safer and more efficient.



TOOL CAPABILITIES

ALIGNING FORCE

with 700bar (10,000psi) hydraulic pressure applied:

- 150kN (15T)

APPLICATION RANGE

- Minimum Bolt Hole Diameter: 45.0mm (1.78")
- Misalignment: 0.0mm - 65.0mm (0.00" - 2.56")

3. NUT SPLITTING SOLUTIONS

DESIGNED TO MEET THE CHALLENGES OF BOLTED PIPE-LINE FLANGE JOINTS

NEW
PRODUCT



A single heat-treated tool-steel cutting tip has achieved 100 cuts of high-grade heavy hex nuts





High strength revolving Composite handle for vibration and shock isolation allows for safer working.

Integrated steel shroud to enclose the cutting zone and protect against flying particles

Optimised Cutting head geometry allowing the nut splitter to be used on a wide range of flange joints; including ones that were previously too tight for nut splitters to fit.

The NS tool range includes a selection of 'TI' Integral Hydraulic tools which feature Equalizer's proven small pump built into the back end of the tool; useful for subsea applications and when working at heights. No need for hoses, separate hand-pumps or couplings.

Drop-tested revolving anchor point and high-strength safety bond included as standard



The combination of the sharp cutting tip and opposing convex reaction point encourages more efficient splitting by spreading the nut open rather than squashing the nut onto the stud. This makes it easier to rotate the nut for the second cut.

Integral hydraulic cylinder and high grade materials make this the smallest and lightest nut splitter on the market

Quick and easy cutting tip replacement

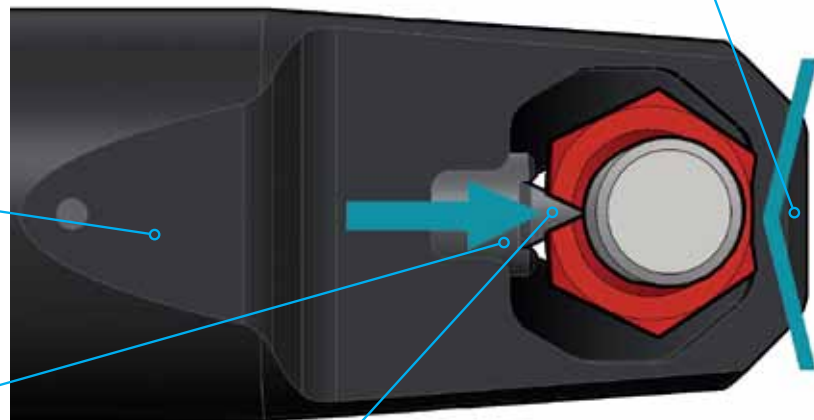

Cutting tip made from heat-treated shock-resisting tool steel for better cut and longer life

NEW
PRODUCT

NS12TE NS12TI

HYDRAULIC NUT SPLITTER

The smallest nut-splitter in the range has 12T (120kN) of splitting force and suits nuts sized between 21mm and 27mm (0.83" and 1.06") across flats. It is available as an external hydraulic version (NS12TE) or as an integral hydraulic version (NS12TI).



INTEGRAL HYDRAULIC 'TI' TYPE
NUTSPLITTER



EXTERNAL HYDRAULIC 'TE' TYPE
NUTSPLITTER

APPLICATION RANGE

- Imperial Standard Nuts:
9/16"; 5/8"
- Imperial Heavy Nuts:
1/2"; 9/16"; 5/8"
- Metric Nuts:
M14; M16

TOOL WEIGHT

- NS12TE: 3.5kg (7.7lb)
- NS12TI: 5.7kg (12.6lb)

NS15TE NS15TI

HYDRAULIC NUT SPLITTER

NS20TE NS20TI

HYDRAULIC NUT SPLITTER

NS36TE

EXTERNAL HYDRAULIC NUT SPLITTER

The 15T (150kN) nut-splitter suits nuts sized between 24mm and 36mm (0.94" and 1.42") across flats. It is available as an external hydraulic version (NS15TE) or as an integral hydraulic version (NS15TI).

The 20T (200kN) nut-splitter suits nuts sized between 36mm and 50mm (1.42" and 1.97") across flats. It is available as an external hydraulic version (NS20TE) or as an integral hydraulic version (NS20TI).

The 36T (360kN) nut-splitter suits nuts sized between 50mm and 65mm (1.97" and 2.56") across flats. It is only available as an external hydraulic tool (NS36TE).

APPLICATION RANGE

- Imperial Standard Nuts:
5/8"; 3/4"; 7/8"
- Imperial Heavy Nuts:
9/16"; 5/8"; 3/4"; 7/8"
- Metric Nuts:
M16; M20; M22

TOOL WEIGHT

- NS15TE: 4.0kg (8.8lb)
- NS15TI: 6.3kg (13.9lb)

APPLICATION RANGE

- Imperial Standard Nuts:
1"; 1-1/8"; 1-1/4";
- Imperial Heavy Nuts:
7/8"; 1"; 1-1/8"; 1-1/4";
- Metric Nuts:
M24; M30

TOOL WEIGHT

- NS20TE: 6.9kg (15.2lb)
- NS20TI: 9.4kg (20.7lb)

APPLICATION RANGE

- Imperial Standard Nuts:
1-3/8"; 1-1/2"; 1-5/8"
- Imperial Heavy Nuts:
1-1/4"; 1-3/8"; 1-1/2";
1-5/8"
- Metric Nuts:
M36; M42

TOOL WEIGHT

- 10.6kg (23.4lb)

4. FLANGE PULLING SOLUTIONS

The Equalizer™ FC10TE Flange Pulling Tool is a simple, lightweight hydraulic tool used to pull together flanges prior to the application of bolts.

The Equalizer™ FC10TE can pull flanges from a distance of 600.0mm (23.62") down to 0.0mm (0.00")

with a force of 200kN (20T) when used as recommended in pairs.

Any number of FC10TE tools can be used simultaneously to provide greater pulling loads.



APPLICATIONS

The FC10TE can be used during:

- commissioning
- construction
- routine maintenance
- shut-downs or outages
- valve change-outs

OPERATING BENEFITS

- reduction in operator fatigue
- reduction in pinch-points
- quick and easy to use
- controllable pulling for flanges or any other heavy equipment

SPECIAL FEATURES

- ratchet nut system
- small footprint
- can be used on all vertical and horizontal flanges including ANSI/ASME, API, BS, DIN & SPO
- pulling force of 100kN (10T)
- pulling force of 200kN (20T) when used in pairs
- robust yet lightweight
- reciprocating hydraulic action



FC10TE

HYDRAULIC FLANGE PULLING TOOL

This low profile tool utilises tandem hydraulic cylinders to offer 10T of closing force and is ideal for use on flanges where access is limited.



TOOL CAPABILITIES

CLOSING FORCE

with 700bar (10,000psi) hydraulic pressure applied:

- 100kN (10T) per tool

APPLICATION RANGE

- Minimum Bolt Hole Diameter: 22.0mm (0.87)
- Closing Distance: 600.0mm (23.6")
down to 0.0mm (0.0")

TOOL WEIGHT

- 11.0kg (24.25lb)

Available in two kit formats:
(MAXI KIT shown far left)



STANDARD KIT

5. PRECISION LIFTING SOLUTIONS

Designed to lift or lower objects in a controlled manner, the VLW range will give a safe, smooth, secure hold when lifting or lowering heavy equipment.

Using the Equalizer™ interlocking first-step technology, this tool will lift an object in a stable movement from an access gap of only 9.5mm (0.37”).



VLW18TE
Actuated by an external hydraulic hand-pump



VLW18TI
Actuated by an integral hydraulic hand-pump, so no hoses or external pumps are required

SPECIAL FEATURES

- smooth, straight, vertical lift
- operates with an access gap of only 9.5mm (0.37”)
- each step offers 19.0mm (0.75”) of vertical lift
- maximum lift using stepped block 67.5mm (2.66”)
- single acting ram
- lifting force of 180kN (18T)
- automatic manual retraction
- interlocking first step



VLW18TI
STANDARD KIT



VLW18TE
STANDARD KIT

6 ■ HYDRAULIC HAND-PUMPS

The Equalizer™ range of hydraulic hand-pumps have been designed with a sealed oil reservoir, which allows the pumps to be used in any orientation without the risk of oil spills or air contamination.

The pumps can be used to operate any 700bar (10,000psi) rated hydraulic equipment in most environments including onshore, topside or sub-sea.

Single-port hand-pumps are used for actuating one single acting cylinder.

Twin-port hand-pumps are used for actuating two single acting cylinders simultaneously.

Double-acting hand-pumps are used for actuating one double-acting cylinder.



OPERATING BENEFITS

- universal orientation
- no oil spillage
- no air contamination
- each pump is available in 350cc, 550cc and 1000cc capacity versions

SPECIAL FEATURES

- two speed
- lightweight
- sealed unit
- hand-held
- retractable/expandable oil reservoir
- pressure rating of 700bar (10,000psi)
- environmentally friendly



'S' TYPE SINGLE ACTING HAND-PUMP



'D' TYPE TWIN-PORT HAND-PUMP



'SD' TYPE DOUBLE-ACTING HAND-PUMP

7. PRODUCT TRAINING

Equalizer International designs and builds products of the highest quality, using the best components. This quality ethos extends to training and a range of training components are offered to ensure the optimal use of the tools. In addition to online training materials, Equalizer

International has built a demo suite at their HQ and has created a mobile demo trailer which travels around providing on-site introductions and training. Through this, users can experience first-hand how quick, simple and easy the tools are to apply and use on a series of custom-built flanges.



ONSITE TRAINING SYSTEM

- custom built trailer, containing the full range of Equalizer™ tools
- Portable training rig with flange joints
- Flange aligning, spreading and pulling tool demonstrations





CLASS-ROOM BASED TRAINING

Commercial and technical presentations provide distributors with the necessary information to respond to a wide range of customer enquiries and challenges.



HANDS-ON TRAINING FACILITY

Practical demonstrations and hands-on training provide distributors and customers with valuable knowledge, information and experience to safely use the full range of Equalizer™ products.

This in turn strengthens Equalizer International's reputation as the expert in tools for flange maintenance within the oil and gas, chemical, power generation, nuclear, water, mining and renewable energy sectors world-wide.

8 . ONLINE SUPPORT

Equalizer offers a range of online support for customers and distributors.

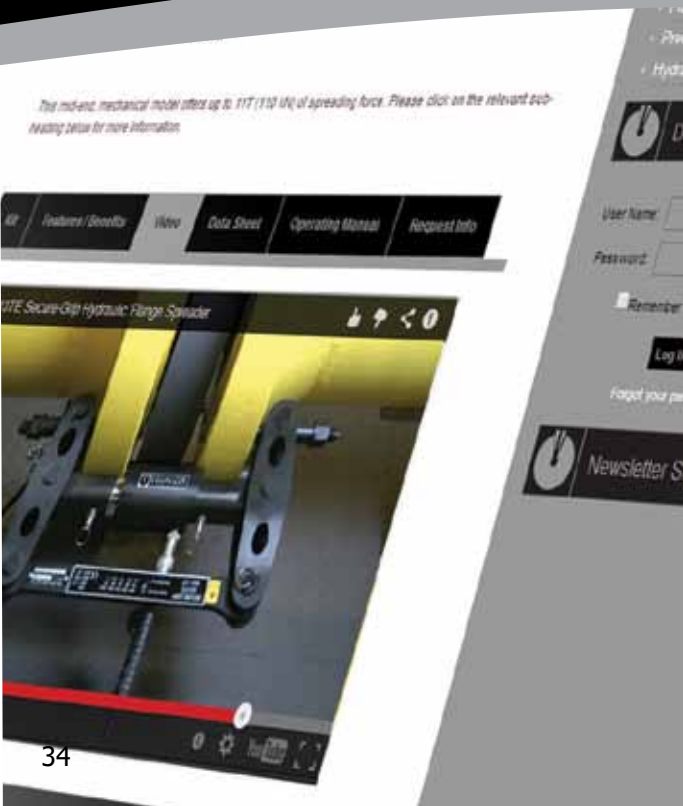

MANUALS & DATA SHEETS

- up-to-date product documentation
- download, save or print

YOUTUBE PRODUCT VIDEOS

- watch each Equalizer™ tool being used in real-time
- watch videos directly from within product pages for easy cross-referencing

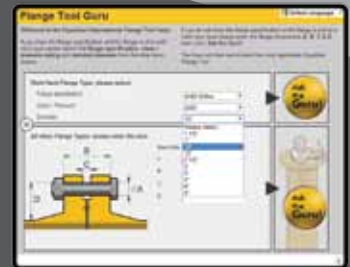

FLANGE TOOL GURU

Online tool to help select the most appropriate Equalizer™ tool. Using a series of drop-down menus or manual entry, users can quickly and easily identify the most appropriate tool(s) for their flange maintenance requirements.

Why not try it out at:

www.equalizerinternational.com

9. GLOBAL DISTRIBUTION

Global interest in Equalizer's flange maintenance tools has led the company to invest heavily in building a network of international distributors; local experts who help advise and select the most relevant flange maintenance tool.

These companies undertake specialist training on the use of Equalizer™ tools and are well equipped to show users how to

get the best out of them. In addition to selling, the distributors provide an after-sale parts service and work with Equalizer's Scottish Head Office to fulfil any spare parts requests. The map below indicates the countries and locations of our distributors – please refer to the Equalizer website for specific contact details.

www.equalizerinternational.com





FLANGE TOOL INNOVATION

EQUALIZER INTERNATIONAL LTD

Head Office:
Equalizer House
Claymore Drive, Aberdeen
Scotland, UK, AB23 8GD

t: +44 (0) 1224 701970
f: +44 (0) 1224 823791

info@equalizerinternational.com
www.equalizerinternational.com



FLANGE TOOL INNOVATION

**EQUALIZER INTERNATIONAL
(AMERICAS), INC.**

1330 Yale Street
Houston TX 77008
USA

t: +1 (713) 927-1840

info@equalizeramericas.com



FLANGE TOOL INNOVATION

**EQUALIZER
FLANGE TOOL INNOVATION
(ASIA) CO., LTD.**

No. 363 | Lane 888
Yongchun South Road | Nantun District
Taichung | Taiwan | 40852 R.O.C.
t: +886-4-2382-7366
f: +886-4-2382-7355

info@equalizerasia.com

DISTRIBUTOR STAMP:

Enerteq Solutions, Inc
Houston Texas, USA
+1 (713) 931 1840

